

the OUTDOOR
FOCUS.

IMAGO®











Corradi
OUTDOOR LIVING SPACE

IMAGO®

Colours | Colori | Coloris | Farben | Colores | Kleuren

vw

<p>Maximum dimensions single module Dimensioni massime modulo singolo Dimensions max. Module unique Max. Abmessungen einzelnes modul Dimensiones máximas módulo individual Max. Afmetingen enkele module</p>	<p>500 x 627 cm 400 x 700 cm (Span x Pivot)</p>		<p>5400 L/h 2 Drains open 2 Scarichi aperti 2 Écoulements ouverts 2 Offene abflüsse 2 Desagües abiertos 2 Open afvoeren</p>
<p>Pillar section Sezione pilastri Section de pilier Querschnitt der pfosten Sección de columna Doorsnede staanders</p>	<p>15 x 15 cm</p>		<p>110 Kg / m² (dim. 500 x 627 x 300 h cm)</p>
<p>Beam section Sezione trave Poutre de section Stützbalken Sección de la viga Draagbalkgedeelte</p>	<p>25 x 15 cm</p>		<p>6 With closed blades A lamelle chiuse Avec lames fermées Mit geschlossenen Lamellen Con lamas cerrada Bij gesloten lamellen</p> <hr/> <p>3 With open blades A lamelle aperte Avec lames ouvertes Mit offenen Lamellen Con lamas abiertas Open lamellen</p>
<p>Blade passage Passo lame L'étape des lamelles Lamellenabstand Paso de la lama Afstand tussen lamellen</p>	<p>21,5 cm</p>		<p>Opt</p>
<p>Integrated gutters Gronda integrate Gouttières intégrées Integrierte rinnen Canalones integrados Geïntegreerde dakgoten</p>	<p>(Span & Pivot)</p>		<p>Master Somfy IO</p>
<p>Blade passage Passo lame L'étape des lamelles Lamellenabstand Paso de la lama Afstand tussen lamellen</p>	<p>21,5 cm</p>		<p>Opt</p>
<p>Integrated gutters Gronda integrate Gouttières intégrées Integrierte rinnen Canalones integrados Geïntegreerde dakgoten</p>	<p>(Span & Pivot)</p>		<p>Opt</p>
<p>Integrated gutters Gronda integrate Gouttières intégrées Integrierte rinnen Canalones integrados Geïntegreerde dakgoten</p>	<p>(Span & Pivot)</p>		<p>Opt</p>
<p>Integrated gutters Gronda integrate Gouttières intégrées Integrierte rinnen Canalones integrados Geïntegreerde dakgoten</p>	<p>(Span & Pivot)</p>		<p>Opt</p>

The maximum permissible load is calculated with closed blades and 275 cm of height passage, thus in the worst-case situation. In case of snow, it is advisable to position the blades at 90° to avoid excessive accumulations. | Il carico massimo ammissibile è calcolato a lamelle chiuse e a 275 cm di passaggio, quindi nella situazione più sfavorevole. In caso di neve è comunque consigliabile posizionare le lamelle a 90° per evitare eccessivi accumuli. | La charge maximale admissible est calculée sur des lamelles fermées et avec 275 cm de passage, donc dans la situation la plus défavorable. | En cas de neige, il est alors conseillé de mettre les lamelles à 90° pour éviter des accumulations excessives. | Die maximale Belastung ist auf einen Zustand mit geschlossenen Lamellen und 275 cm Durchgang berechnet. Bei Schnee ist es ratsam, die Lamellen auf 90° zu stellen, um eine übermäßige Anhäufung zu vermeiden. | a carga máxima admisible se calcula con las lamas cerradas, y a 275 cm de paso, en la situación más desfavorable. En caso de nieve, es aconsejable poner las lamas en posición a 90°, para evitar la sobre carga. | De maximaal toelaatbare lading is berekend voor gesloten lamellen en een doorgang van 275 cm, dus in het meest ongunstige geval. Wanneer het sneeuwt is het in elk geval raadzaam de lamellen 90° open te zetten, om buitenmatige ophopingen te vermijden.

AL

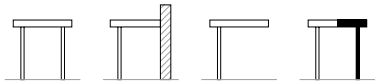

Corradi
OUTDOOR LIVING SPACE

MONOCHROME

BICOLOR CLASSIC

BICOLOR COCOON

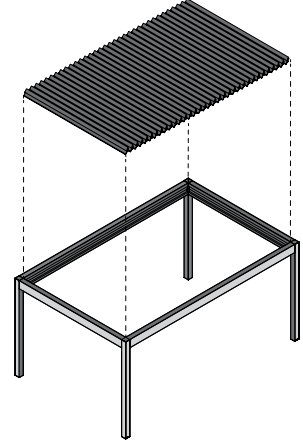
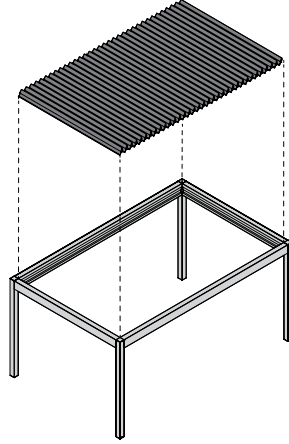
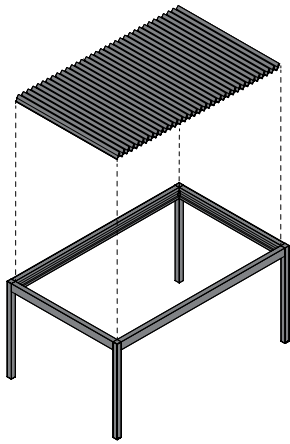

SINGLE MODULE
MODULO SINGOLO
MODULE SIMPLE
EINZELMODUL
MÓDULO INDIVIDUAL
ENKELE MODULEV

LONGITUDINAL DOUBLE MODULE
MODULO DOPPIO LONGITUDINALE
MODULE DOUBLE LONGITUDINAL
DOPPEL MODUL LÄNGSSTEHEND
MÓDULO DOBLE LONGITUDINAL
DUBBELE MODULE AAN
DE SPANZIJDE GEKOPPELD

FRONTAL DOUBLE MODULE
MODULO DOPPIO FRONTALE
MODULE DOUBLE FRONTAL
DOPPEL MODUL STIRNSEITIG
MÓDULO DOBLE FRONTAL
DUBBELE MODULE AAN
DE PIVOTZIJDE FRONTALE MODULE

Freestanding
Autoportante
Autoportante
Freistehend
Autoportante
Zelfdragend

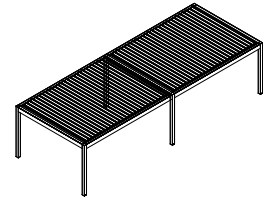
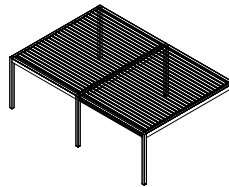
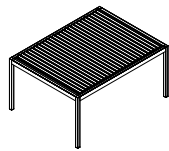

Longitudinal wall-mounted
Addossata longitudinale
Adossée longitudinale
Längsangebaut
Adosada longitudinal
Aangebouwd in lengterichting

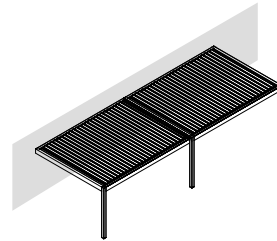
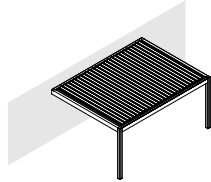

Wall-mounted
Addossata
Adossée
Angebaut
Adosada
Aangebouwd

