

the OUTDOOR **HER
OES.**

edition .23

EN | IT

—IMAGO®



corradi.eu

Corradi
OUTDOOR LIVING SPACE

ABOUT CORRADI

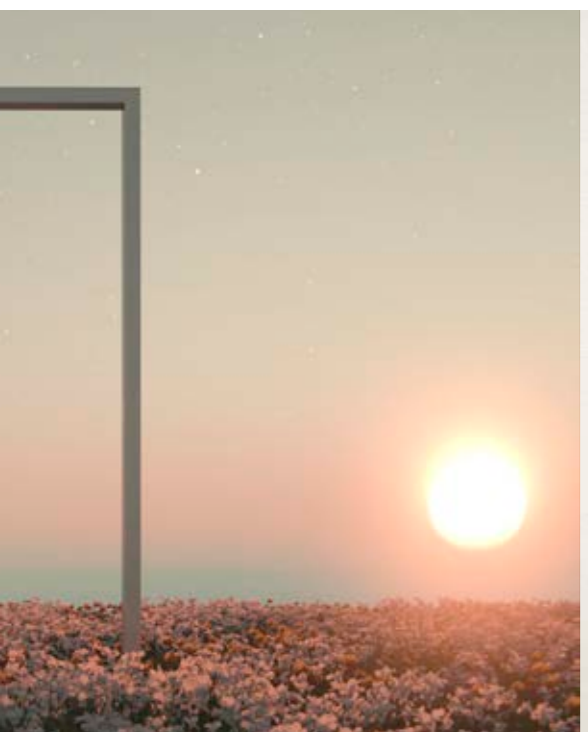
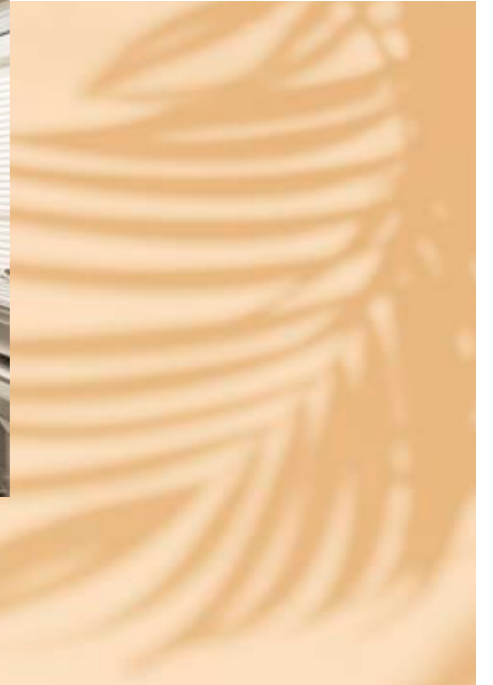

EN FOR MORE THAN 40 YEARS WE HAVE BEEN DESIGNING SOLUTIONS THAT ALLOW YOU TO ENJOY THE OUTDOORS AT BEST.

We have come a long way from the small 45-year-old artisanal workshop to today's company that uses the best production technologies and distributes products throughout the world. What has never changed is our determination and passion, just like the first day. Our desire to always do better, develop new ideas, seek out other points of view. Our desire to create your future outdoor space.

IT DA OLTRE 40 ANNI PROGETTIAMO SOLUZIONI PER FARTI VIVERE AL MEGLIO LO SPAZIO ESTERNO.

Ne abbiamo fatta di strada, dal piccolo laboratorio artigianale di 45 anni fa all'azienda di oggi, che utilizza le migliori tecnologie produttive e distribuisce i prodotti in tutto il mondo. Ciò che non è mai cambiato sono la nostra grinta e la nostra passione, proprio come il primo giorno. Il desiderio di fare sempre meglio, di sviluppare nuove idee, di cercare altri punti di vista. Il desiderio di creare il tuo spazio esterno di domani.



_____ solutions to
create
your
outdoor space

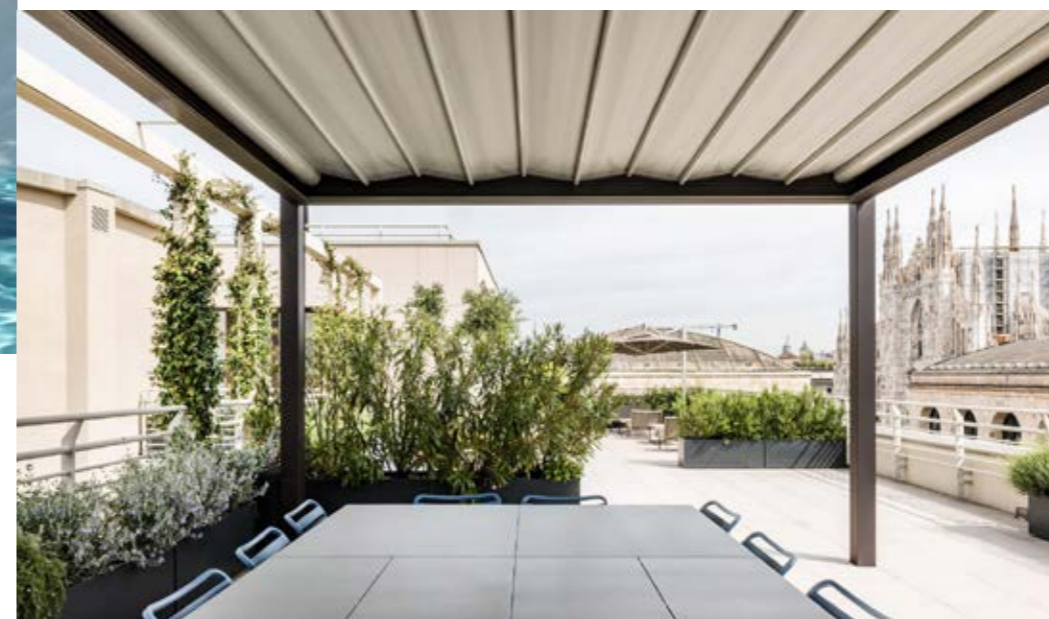
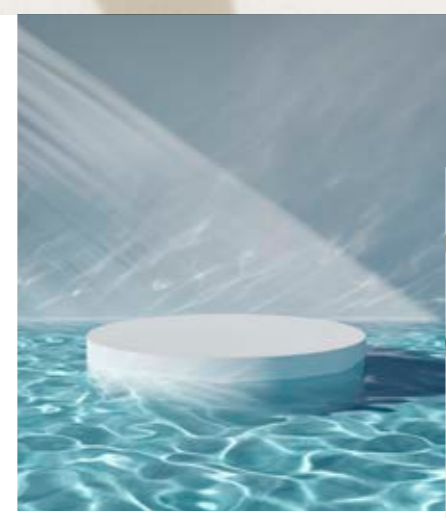

Corradi
OUTDOOR LIVING SPACE



IMAGO®



reddot winner 2020



Look at the sky

EN IMAGO® IS THE CORRADI PROJECT BORN FROM A NEW VISION OF THE EXTERNAL SPACE WITH RESPECT TO ITS USE, WHAT HAPPENS THERE, WHAT YOU CAN IMAGINE DOING.

It is the interpretation of the outdoors as a space for living outside the home, conceived as an autonomous, malleable entity that within carries Corradi DNA made of experience, innovation, emotion and Italian design.

IT IMAGO® È IL PROGETTO CORRADI NATO DA UNA VISIONE INEDITA DELLO SPAZIO ESTERNO RISPETTO AL SUO UTILIZZO, A CIÒ CHE VI ACCADE, A CIÒ CHE SI PUÒ IMMAGINARE DI FARE.

E' l'interpretazione dell'outdoor inteso come spazio dell'abitare fuori dalla casa, pensato quale entità autonoma e duttile, che porta al suo interno il DNA Corradi fatto di esperienza, innovazione, emozione e design italiano.

IMAGO®



Bi-color Cocoon



Fixed panels
Pannelli fissi



EN Imago® goes beyond the concept of outdoor products to enter the dimension of place. A solution with adjustable blades up to 135°, self-sufficient for its construction details: platform, pillars, beams in full architectural continuity. Design pushed to extreme simplicity.

IT Imago® supera il concetto di prodotto outdoor, per entrare nella dimensione del luogo. Una soluzione a lamelle orientabili fino a 135°, autosufficiente per dettagli costruttivi: pedana, pilastri, travi in piena continuità architettonica tra loro. Il design spinto all'estrema pulizia.



EN The main configuration of Imago® is self-supporting, but it is also possible to place the structure against the wall. With a cross-section of 15 x 15 cm, the pillars were designed to accommodate both a downpipe that directs the drainage of water and side runners of screens, for a maximum encumbrance of 33 x 33 mm. The pillars can also integrate electrical and USB sockets.

IT La configurazione principale di Imago® è autoportante, ma è possibile anche addossare la struttura al muro. I pilastri, di sezione 15 x 15 cm, sono stati concepiti per ospitare sia un pluviale che indirizza il deflusso dell'acqua sia le guide laterali degli screen - per un massimo ingombro di 33 x 33 mm. I pilastri possono inoltre integrare prese elettriche e connessioni usb.

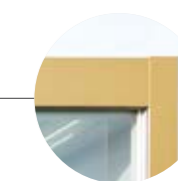

Architectural continuity
Continuità architettonica



IMAGO®

EN The 15 x 25 cm beams are also designed to incorporate runners for sliding glass doors and the retractable canvas of vertical closures, concealing any discontinuity from view. Indeed, the blades' controls are also situated on the inside of the beam to protect the motorised drive mechanism, maximising aesthetics and practicality. The blades have been completely redesigned to mesh better with the simple continuity of the lines. In fact, they are flat, measure 24,5 by 4,8 cm (space between blades 21,5 cm) and can accommodate dimming LED lights, perfectly centred with respect to the blade width.

IT Le travi, 15 x 25 cm, sono anch'esse pensate per integrare tutte le chiusure della gamma, nascondendo alla vista ogni discontinuità. In questo modo anche la barra di comando del sistema a lamelle trova collocazione sul lato interno della trave per proteggere il meccanismo di azionamento motorizzato, massimizzando estetica e funzionalità. Le lamelle sono state completamente ridisegnate, per dare risposta al desiderio di pulizia e continuità delle linee. Sono infatti piatte, di dimensioni 24,5 per 4,8 cm (passo tra le lame 21,5 cm) e in grado di accogliere luce led dimmerabili, perfettamente centrate rispetto alla larghezza della lama.



IMAGO®

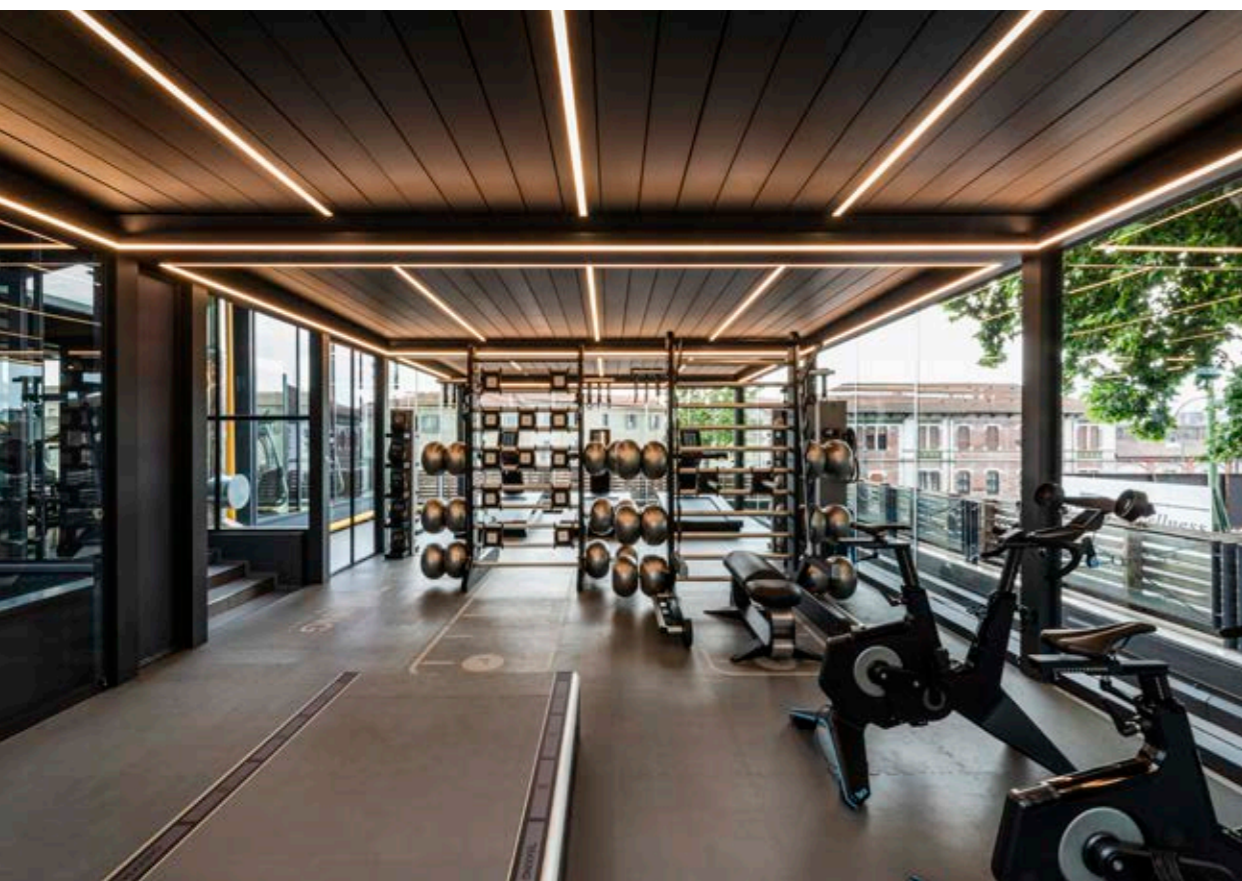

EN The gutter gives the possibility of incorporating LED lights throughout the entire internal perimeter to create a modular, effective and particularly pleasant lighting system.

IT La gronda dà la possibilità di integrare luci led su tutto il perimetro interno e creare un sistema di illuminazione modulabile, efficace e particolarmente piacevole.



Private module

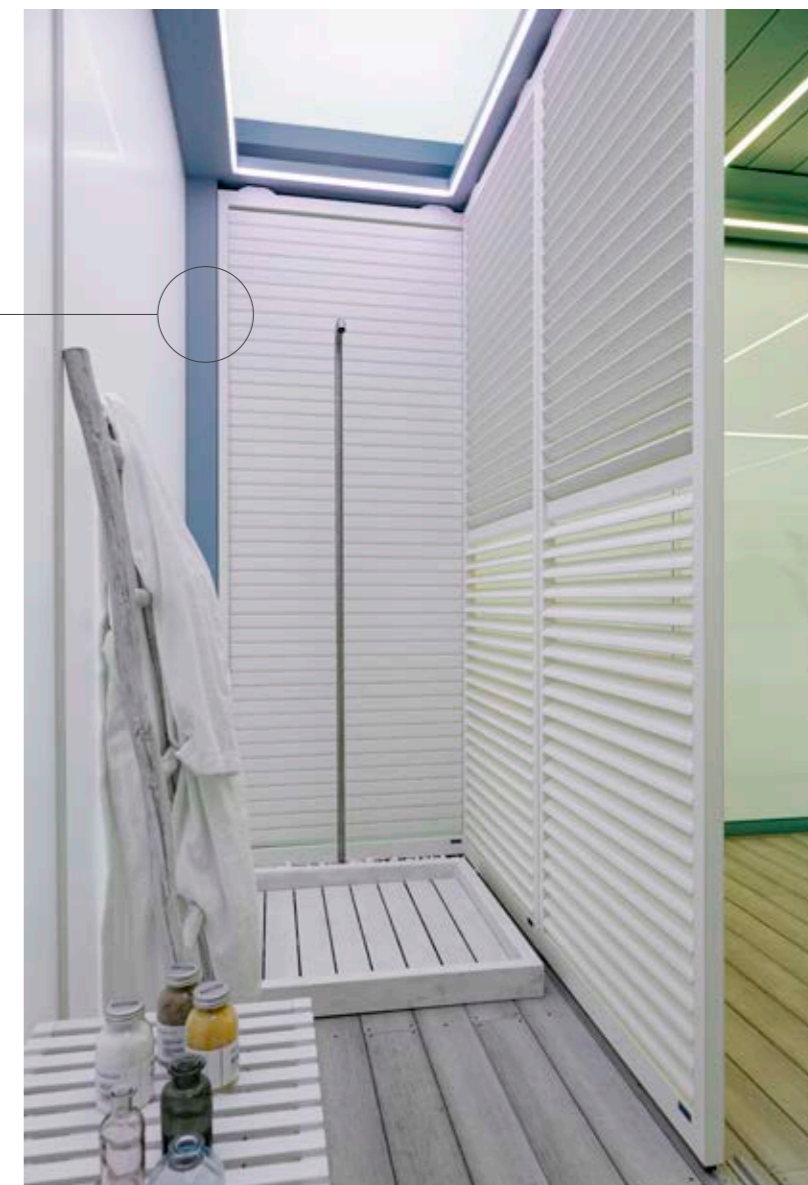

EN The particular geometry of the beams and pillars means that Imago®'s external skin can be completely different in colour from the interior for an original, welcoming bi-color effect.

IT La particolare geometria di travi e pilastri fa sì che la pelle esterna di Imago® possa essere di colore completamente diversa da quella interna, per un effetto bicolore originale e accogliente.

IMAGO®

EN Imago® also shows off its superior level of integration and flexibility with its many configurations of side closures:

- Fully open on the sides for total permeability
- Closed with sliding glass doors
- Closed with Aura brise-soleil
- Closed with vertical screen with transparent, filtering or shuttering canvas
- Dual closure, with glasses and vertical screens
- Closed by using fixed panels, full or pierced tinplate

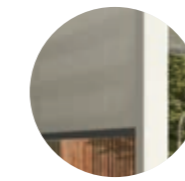

Q Double fully integrated closure
Doppia chiusura integrata



Q Anti-splash system
Sistema antirimbazzo

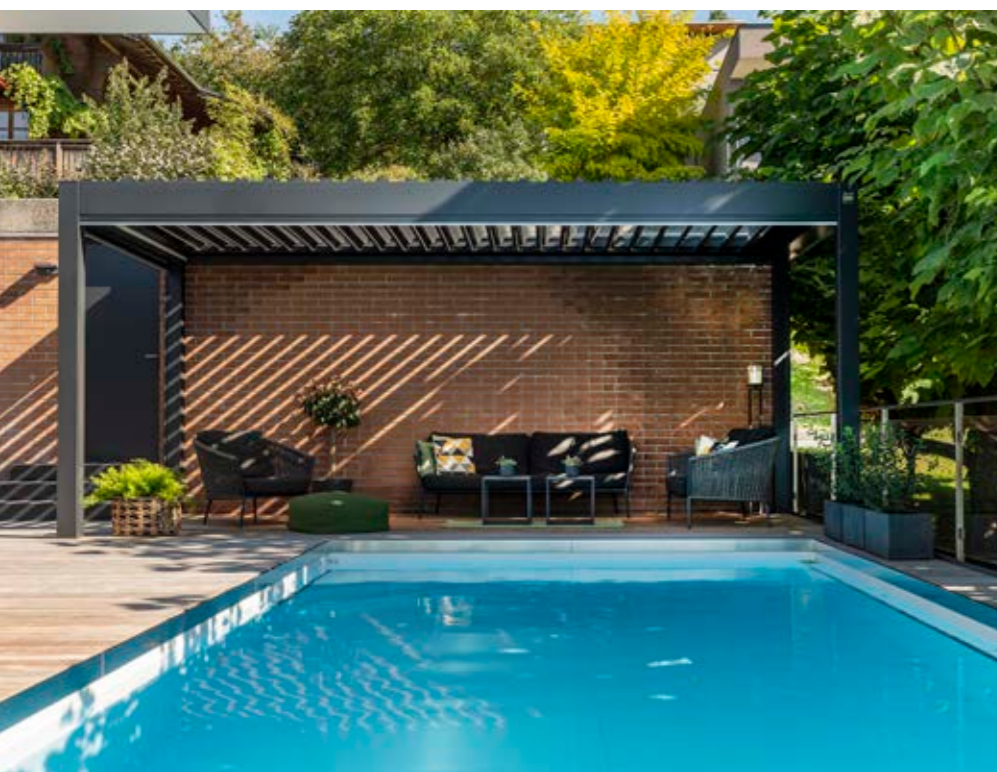

IT Integrazione e flessibilità si ritrovano anche nelle molteplici configurazioni che Imago® può avere rispetto alle chiusure laterali:

- Completamente aperto sul perimetro, per una permeabilità totale
- Chiuso con vetrate scorrevoli
- Chiuso con brise soleil Aura
- Chiuso con screen verticali a telo trasparente, filtrante o oscurante
- Doppia chiusura, con vetrate e screen verticali
- Chiuso tramite l'utilizzo di pannelli fissi, a lamiera piena o forata

EN Imago®'s interior spaces can be modulated according to the function they are designed for, also thanks to the optional Private and Look at the sky: Private is a private corner that can be used as a dressing room, storage for chairs and loungers, wardrobe, table settings... consists of a partition of fixed and sliding brise-soleil panels secured to an additional intermediate beam and a fixed transparent Plexiglass cover (Look at the sky) to allow illumination from above. Look at the sky, resistant to UV rays and bad weather, is also available without the Private module.

IT Gli spazi interni di Imago® possono essere modulati in base alla funzione per la quale sono concepiti, anche grazie a gli optional Private e Look at the sky: Private è un angolo privato che può essere utilizzato come spogliatoio, rimessaggio per sedie e lettini, guardaroba, stoviglie... E' composto da una partizione di pannelli brise soleil fissi e scorrevoli, fissati a una trave intermedia aggiuntiva e copertura fissa in plexiglass trasparente (Look at the sky) per consentire il passaggio di luce. Look at the sky, resistente ai raggi UV e alle intemperie, è disponibile anche non in combinazione con il modulo Private.

IMAGO®

EN The possibility of shifting the pillar makes Imago® an even more flexible and complete solution, able to adapt to any architectural space.

IT La possibilità di avere il pilastro traslato rende Imago® una soluzione ancora più flessibile e completa, capace di adattarsi al meglio ad ogni spazio architettonico.



Shifted pillar
Pilastro traslato

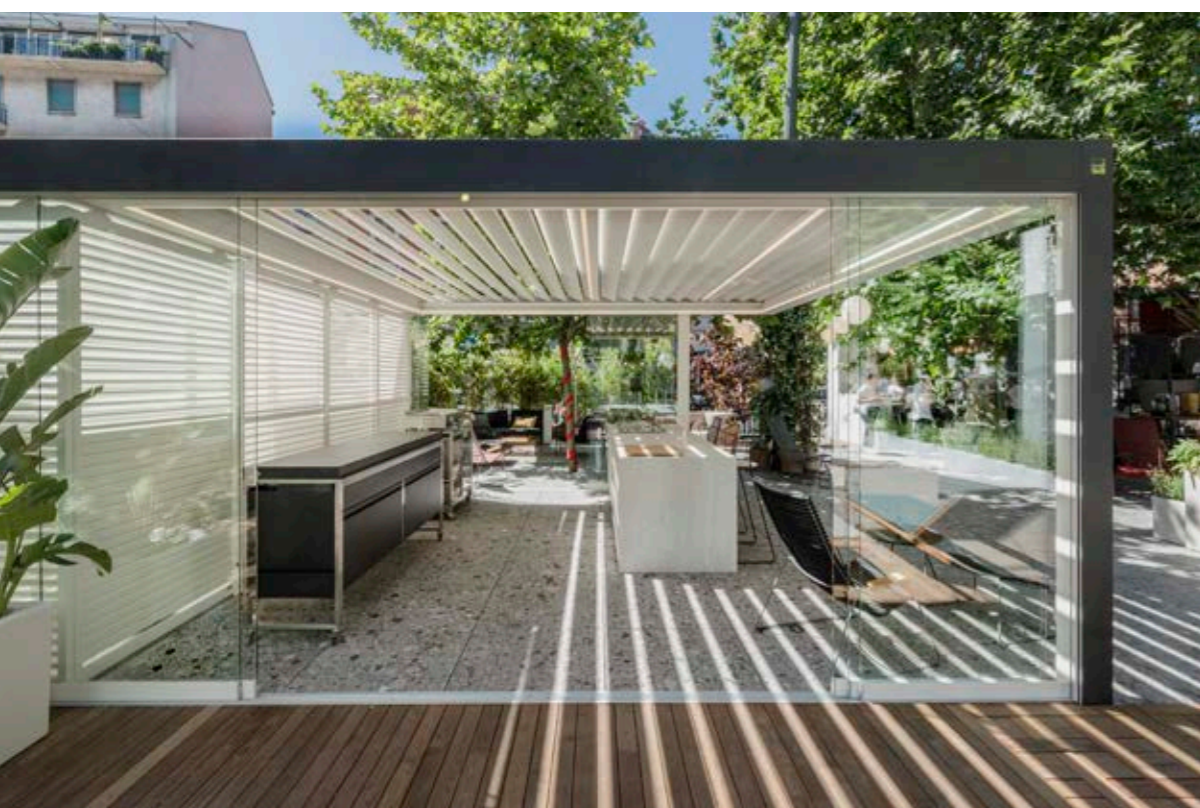

EN To complete the optional components that make Imago® a self-sufficient pavilion, we have developed the new 17,5 cm high Domino platform that can compensate for differences in height, which can be combined with different types of walking surfaces. On request, Imago® is also available without Domino, with the possibility of draining rainwater on all sides.

Imago® is pre-wired with a Master motor (Somfy optional).

IT A completamento degli optional che fanno di Imago® un padiglione autosufficiente, abbiamo sviluppato una nuova pedana Domino alta 17,5 cm con possibilità di compensare dislivelli, alla quale abbinare diverse tipologie di piani di calpestio. A richiesta, Imago® è disponibile anche senza Domino, con possibilità di scarico dell'acqua su tutti i lati.

Imago® è precablato con motorizzazione Master (Somfy opzionale).

HIGHLIGHTS

EN

Customised product

Single module size up to 400 x 700 cm or 500 x 627 cm

Possibility of joining several modules without doubling the pillar

15 x 15 cm pillars and 25 x 15 cm beam

Freestanding or wall-mounted

Blades adjustable up to 135°

Customised according to the required function with Private Module, Look at the Sky and fixed panels

Fully motorised

Side closures fully integrated with vertical screens and sliding glassdoors (also in combination with each other), or with a fixed or sun shade panel

Possibility of one or more retracted pillars for maximum design flexibility

Specially designed Domino deck adjustable in height

Rainwater management via perimeter gutter and downpipe integrated in the pillar

System that prevents water from bouncing back inside in heavy rain

LED lights integrated in the blades and on the perimeter of the gutter

Anemometer and rain sensor

Electrical sockets and USB connections

Motor and screws hidden from view

Special colours with two-tone "cocoon" effect

IT

Prodotto su misura

Dimensioni modulo singolo fino a 400 x 700 cm o 500 x 627 cm

Possibilità di accoppiare più moduli senza raddoppiare il pilastro

Pilastri 15x15 cm e trave 25 x 15 cm

Autoportante o addossata a parete

Lamelle orientabili fino a 135°

Personalizzata in base alla funzione desiderata grazie a Modulo Private, Look at the Sky e pannelli fissi

Completamente motorizzata

Chiusure laterali totalmente integrate con screen verticali e vetrate (anche in abbinamento tra loro), oppure con pannello fisso o frangisole

Possibilità di uno o più pilastri retratti per la massima flessibilità di progetto

Pedana Domino studiata ad hoc regolabile in altezza

Gestione dell'acqua piovana tramite gronda perimetrale e pluviale integrato nel pilastro

Sistema che impedisce il rimbalzo dell'acqua all'interno in caso di forte pioggia

Luci LED integrate nelle lamelle e sul perimetro della gronda

Anemometro e sensore pioggia

Prese elettriche e connessioni usb

Motore e viti nascosti alla vista

Colorazioni particolari con effetto bicolor "cocoon"

IMAGO®

Colours | Colori

Structure (inside/outside) and blades
Struttura (interno/esterno) e lamelle

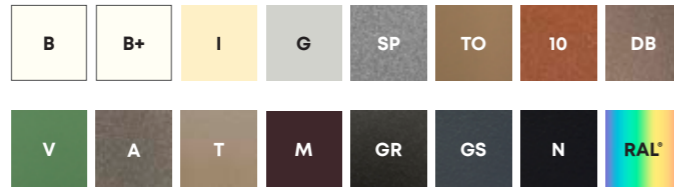



Maximum dimensions single module Dimensioni massime modulo singolo	500 x 627 cm 400 x 700 cm (Span x Pivot)		5400 L/h 2 Drains open 2 Scarichi aperti
			110 Kg / m ² (dim. 500 x 627 x 300 h cm)
Pillar section Sezione pilastri	15 x 15 cm		6 With closed blades A lamelle chiuse class EN 13561 500 x 627 cm 3 With open blades A lamelle aperte
Beam section Sezione trave	25 x 15 cm		Opt
			Master Somfy IO
Blade passage Passo lame	21,5 cm		Opt
			Opt
			Opt
Integrated gutters Gronde integrate	■ (Span & Pivot)		Opt

The maximum permissible load is calculated with closed blades and 275 cm of height passage, thus in the worst-case situation. In case of snow, it is advisable to position the blades at 90° to avoid excessive accumulations.

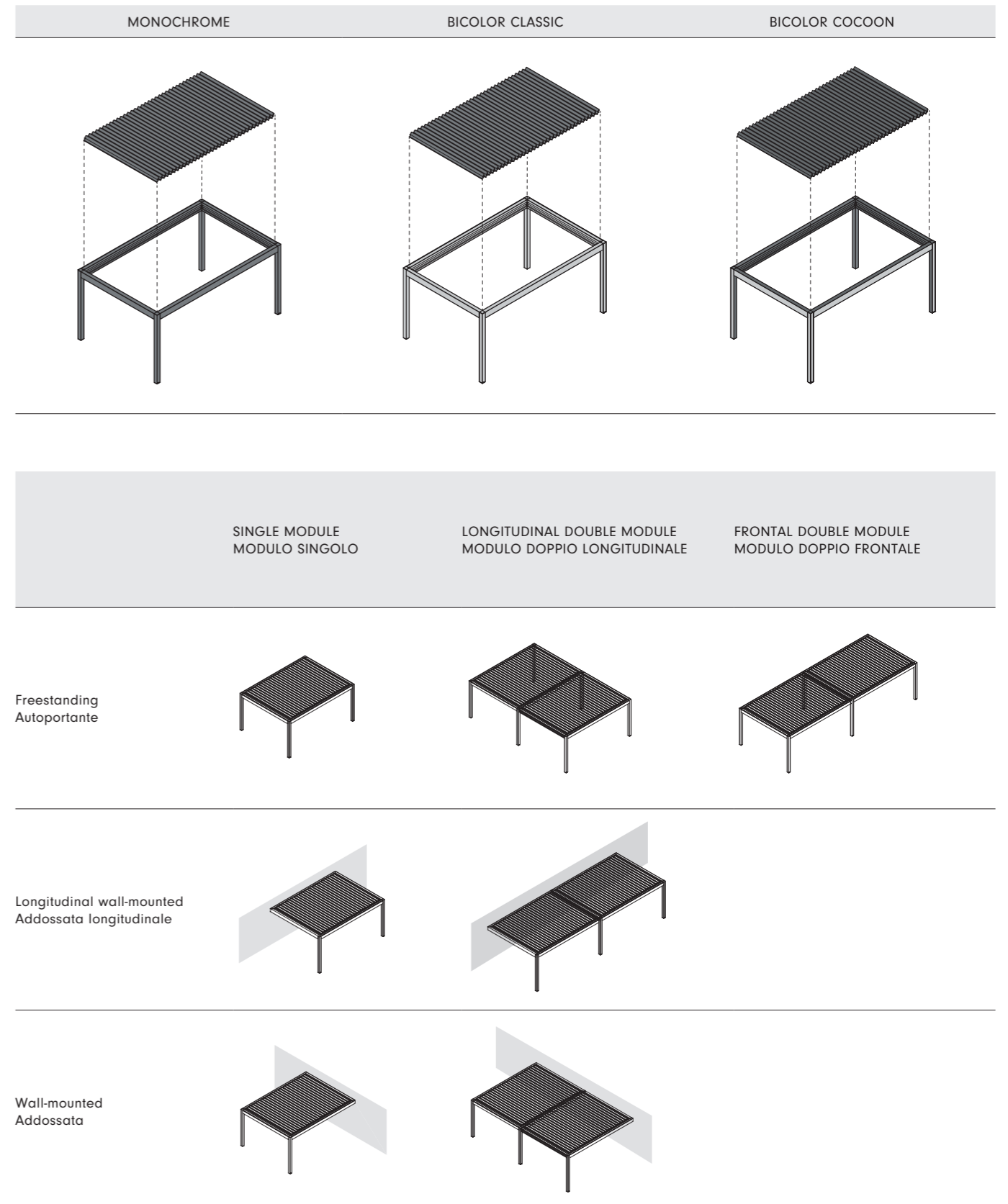
Il carico massimo ammissibile è calcolato a lamelle chiuse e a 275 cm di passaggio, quindi nella situazione più sfavorevole. In caso di neve è comunque consigliabile posizionare le lamelle a 90° per evitare eccessivi accumuli.



IMAGO®

	PIVOT	SPAN
 Multilayer screen system Chiusure multiple	■	■
Look at the sky module	—	Opt
Private module	—	Opt
AL Fixed panels Pannelli fissi	—	Opt
 Light on the perimeter of the gutter Sul perimetro della gronda	Opt	Opt
Rainwater disposal through pillar Scarico acqua integrato nel pilastro	■	■
Electrical and usb sockets integrated in the pillars Presse elettrica e usb integrata nei pilastri	Opt	Opt

Multilayer screen system
Chiusure multiple

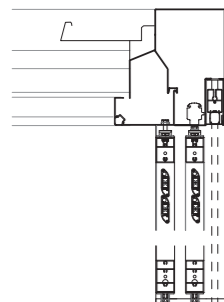

AURA + MAGIKO B

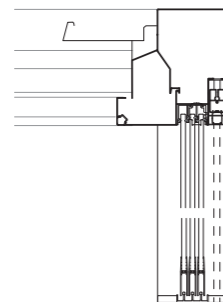

SLIDING GLASSDOORS + MAGIKO B
VETRATE + MAGIKO B



Look at the sky & Private module
Look at the sky e modulo Private

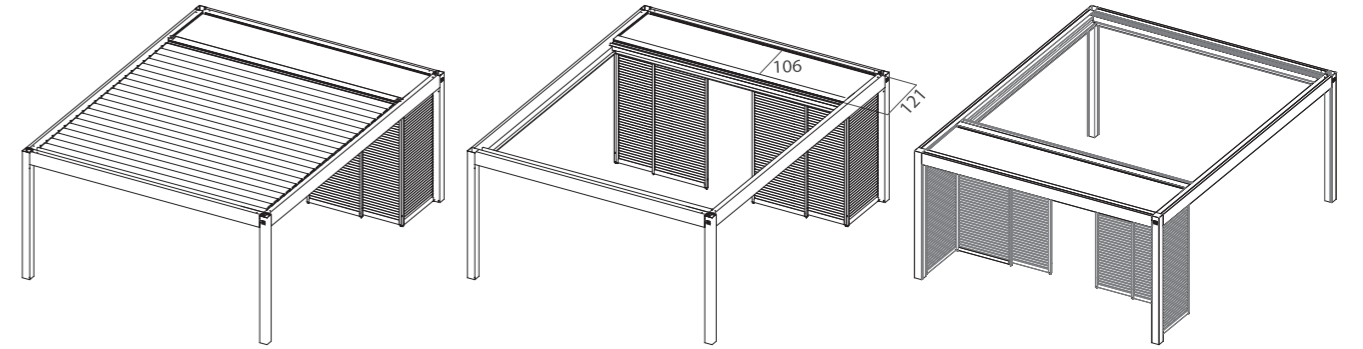

Wall mounted Imago® on span side and additional modules
Imago® addossata a muro lato span e moduli aggiuntivi

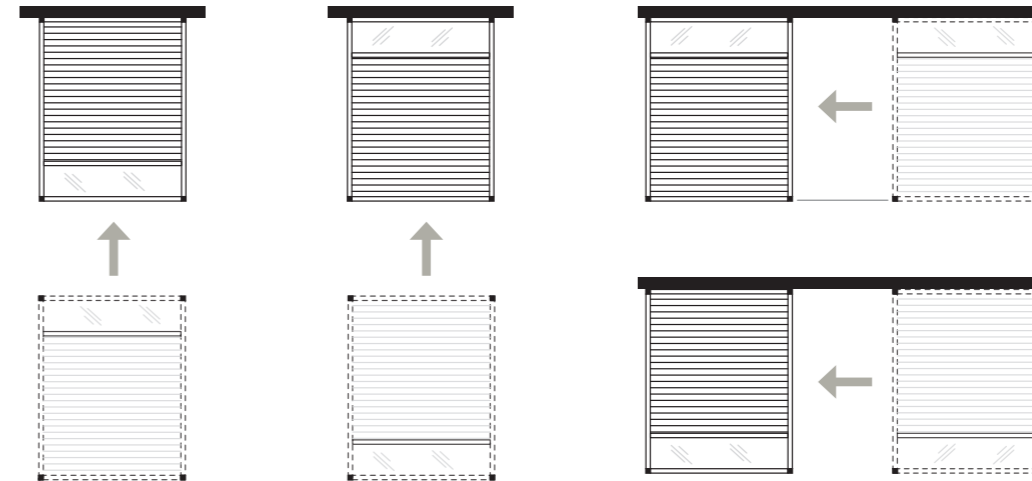

Solution for additional t-shaped module oriented on span side
Soluzione per modulo aggiuntivo a "t" orientato sul lato span

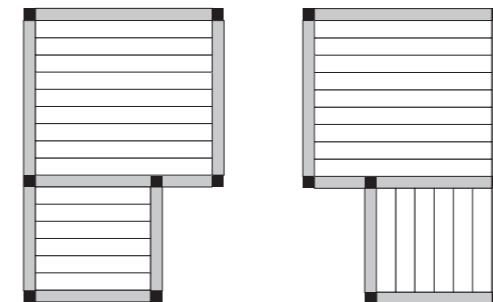

Corradi Srl

Via M. Serenari, 20
40013 Castel Maggiore BO, Italy
T +39 051 4188 411
E hello@corradi.eu

www.corradi.eu

