



Cassette awning

I/K/N 2000

The **I/K2000** is the tried-and-tested, classic cassette awning – as an **I2000** without rear wall for level building facades, as the **K2000** with back plate for uneven bases. The sturdy weinor awning with its carrier bar can be used almost anywhere. As the decor on the front profile and the side caps suggest, the **I/K2000** tends towards a more traditional design. The optional LED light bar makes the awning part of any stylish evening. The **N2000** is literally a niche item: with its projection profile, the awning disappears almost completely into the facade – with simple, straight lines, it is designed to meet a specific need.



Simple installation
With wall bracket
and carrier bar



Wind lock safety device:
Prevents the awning from lifting up
in gusts of wind from below

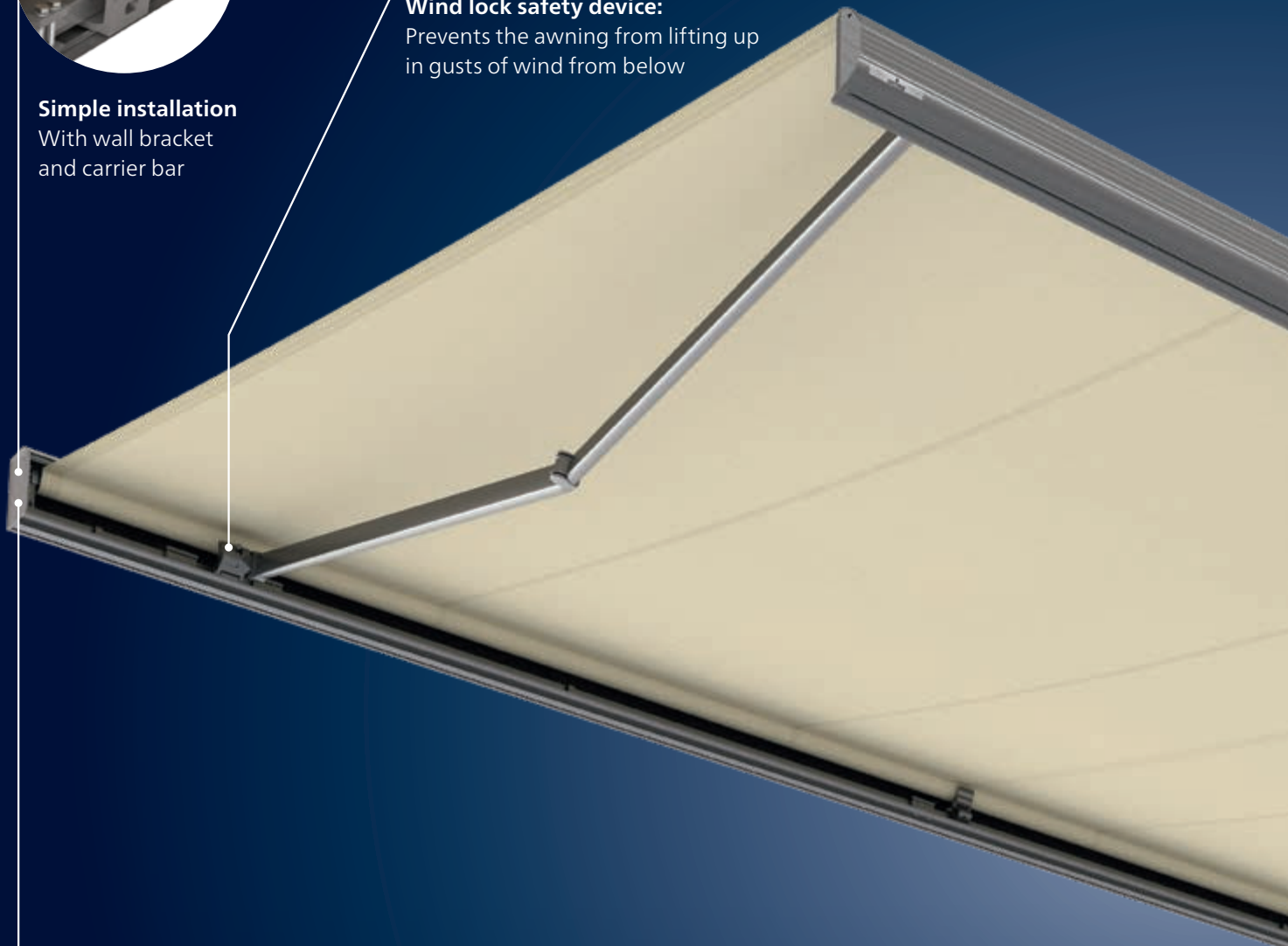

I 2000:
Without back plate



K 2000:
With back plate



N 2000:
For niche installations

I/K/N 2000 Highlights

Coupled/joined units:
With roller supports



or jockey cover



**Optional LED Design
light bar:**
Highly energy-efficient



weinor LongLife arm:
Very durable and
low-noise



I/K/N 2000 Benefits

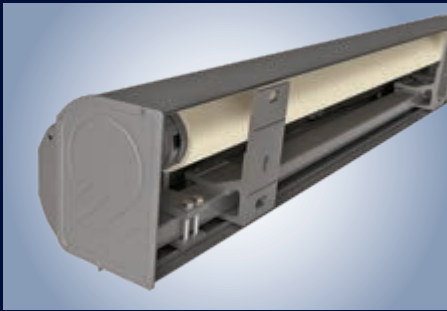

I 2000: open cassette – perfect for wall installation

The I 2000 cassette awning is open on the side facing the wall.

- Extremely well suited to wall mounting, e.g. beneath roof overhangs
- Shapely front profile allows it to close precisely and provide perfect protection for fabric and fittings



K 2000: closed cassette – back plate for extra protection

The K 2000 features an additional rear wall, completely closing it off.

- For every constructional situation
- Back plate profile makes it equally suitable for
 - wall installation
 - ceiling installation
 - rafter installation
 - installation on special brackets



weinor LongLife Arm – durable, quiet operation

The weinor LongLife arm features an exceptionally robust high-tech belt.

- Tested to more than 100,000 cycles
- Extremely quiet operation
- No maintenance required
- Drop forged aluminium in joint – light but highly robust



N 2000: niche cassette – flush to facade installations

- The N 2000 is specially designed for niche installation.
- Embedded in the building facade
 - Edge of front profile fits flush with the building facade
 - Tilting mechanism ensures the front profile closes securely



Wind lock safety device – reliable protection

The ultramodern technology prevents the awning from lifting up when wind gusts from below.

- Patented wind lock safety device
- Via a tilting mechanism, the front profile and awning arm are tilted when ascending
- Proven, maintenance-free technology
- All components made of forged and extruded aluminium

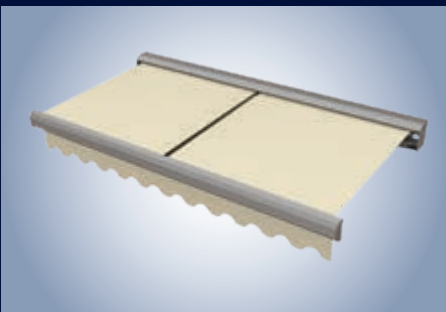

Multi-section units – to shade especially large areas

The I/K 2000 also comes as a combined multi-section unit for very large terraces – coupled or in series.

- As a 2-part unit up to 1,200 cm
- Jockey cover or roller support with continuous fabric

I/K/N 2000 Technology

I/K/N 2000 versions	I/K 2000	N 2000
Technology		
Max. width, 1-section/2-section with jockey cover or roller support	700 cm/1,200 cm	600 cm
Max. projection	400 cm	350 cm
Cassette size (w x h) incl. standard bracket	198/200 mm x 211 mm	210 mm x 197 mm
Coupled systems	○	—
Gear drive	○	○
Motor drive	● as standard	● as standard
Angle of pitch on awning	5° to 40°	5° to 40°
Installation alternatives	can be installed on walls, ceilings and rafters	
LongLife arm	● as standard	● as standard
Accessories		
Heating system Tempura/Tempura Quadra	○	○
LED Design light bar	○	○
BiSens Agido-3V product protection sensor	○	○
Controls		
Radio control	○	○
No remote	●	●
Weather sensors		
Sun/wind sensor	○	○
Sun/wind sensor solar powered	○	○
Sun/wind/rain sensor	○	○
Quality		
Tested up to	wind resistance class 1 according to DIN 13561 (wind strength 5 on the Beaufort scale)	

● standard ○ optional — unavailable

I/K/N 2000 Controls

weinor BiConnect radio controller

Product	Electronics	BiConnect control	Remote receiver	Transmitter
I/K/N 2000	I/K/N 2000 drive	<ul style="list-style-type: none"> • BiRec receiver integrated into cassette 	BiRec MA-K	<ul style="list-style-type: none"> • BiEasy 1M/5M/15M Go! hand transmitter • 1MW-3V wall transmitter
I/K/N 2000 LED	I/K/N 2000 drive and LED lighting	<ul style="list-style-type: none"> • BiRec combi-receiver for main drive and LED light bar (with integrated power supply pack) integrated into light bar • Dimmable LED 	BiRec MA-K and BiRec LED	<ul style="list-style-type: none"> • BiEasy 5M/15M Go! hand transmitter
Accessories (optional)	Tempura/Tempura Quadra heating system	<ul style="list-style-type: none"> • Dimmable, additional receiver required • Installation of the receiver in the design bar provided for this purpose or the Tempura Quadra box 	BiRec HD	<ul style="list-style-type: none"> • BiEasy 5M/15M Go! hand transmitter

Requires: awning with BiConnect remote control and sensors require a BiEasy 1M, 5M or 15M Go!

Somfy io-homecontrol® radio technology

Product	Electronics	Somfy io-homecontrol control	Remote receiver	Transmitter
I/K/N 2000	I/K/N 2000 drive	<ul style="list-style-type: none"> • Somfy io remote-controlled motor integrated into cassette 	Somfy io remote-controlled motor	<ul style="list-style-type: none"> • Situo 1 io Pure II/Situo 5 io Pure II/Situo 5 Variation A/M io Pure II hand transmitter • Smoove 1 io Pure Shine wall transmitter
I/K/N 2000 LED	I/K/N 2000 drive and LED lighting	<ul style="list-style-type: none"> • Somfy io remote-controlled motor integrated into cassette • Additional Somfy receiver for the LED light bar (with downstream power supply pack) integrated into light bar • LED dimmable 	Somfy io remote-controlled motor and io Lighting Receiver Variation (dimmable)	<ul style="list-style-type: none"> • Situo 5 io Pure II/Situo 5 Variation A/M io Pure II hand transmitter
Accessories (optional)	Tempura/Tempura Quadra heating system	<ul style="list-style-type: none"> • Dimmable, additional receiver required • Installation of the receiver in the design bar provided for this purpose or the Tempura Quadra box 	Heating Receiver Variation io 1.5 kW STAS3/STAK3 (dimmable)	<ul style="list-style-type: none"> • Situo 5 io Pure II/Situo 5 Variation io Pure II hand transmitter • Smoove 1 io Pure Shine wall transmitter

Somfy RTS radio technology

Product	Electronics	Somfy RTS control	Remote receiver	Transmitter
I/K/N 2000	I/K/N 2000 drive	<ul style="list-style-type: none"> • Somfy RTS remote-controlled motor integrated into cassette 	Somfy RTS remote-controlled motor	<ul style="list-style-type: none"> • Situo 1 RTS Pure II/Situo 1 Soliris RTS Pure II/Situo 5 RTS Pure II/Situo 5 Soliris RTS Pure II hand transmitter • Smoove 1 RTS Pure Shine wall transmitter
I/K/N 2000 LED	I/K/N 2000 drive and LED lighting	<ul style="list-style-type: none"> • Somfy RTS remote-controlled motor integrated into cassette • Additional Somfy receiver for the LED light bar (with downstream power supply pack) integrated into light bar • LED not dimmable 	Somfy RTS remote-controlled motor and Lighting Slim Receiver RTS	<ul style="list-style-type: none"> • Situo 5 RTS Pure II/Situo 5 Soliris RTS Pure II hand transmitter

I/K/N 2000 Controls

Hard wired with Somfy control

Product	Electronics	Hard wired Somfy control	Control
I/K/N 2000	I/K/N 2000 drive	<ul style="list-style-type: none"> • Somfy control for awning drive 	e.g. Soliris Smooove Uno
I/K/N 2000 LED	I/K/N 2000 drive and LED lighting	<ul style="list-style-type: none"> • Somfy control for awning drive • Switch on site for the LED light bar • LED power supply pack integrated into light bar • LED not dimmable 	e.g. Soliris Smooove Uno and suitable light switch (on site)
Accessories (optional)	Tempura/Tempura Quadra heating system	<ul style="list-style-type: none"> • Not dimmable 	Suitable switch (on site)

Hard wired (existing switch/power supply on site)

Product	Electronics	Hard wired control	Control
I/K/N 2000	I/K/N 2000 drive	<ul style="list-style-type: none"> • Awning switch for the awning drive 	e.g. double rocker switch switch (on site)
I/K/N 2000 LED	I/K/N 2000 drive and LED lighting	<ul style="list-style-type: none"> • Awning switch for the awning drive • Switch on site for the LED light bar • LED power supply pack integrated into light bar • LED not dimmable 	e.g. double rocker switch and suitable light switch (on site)
Accessories (optional)	Tempura/Tempura Quadra heating system	<ul style="list-style-type: none"> • Not dimmable 	Suitable switch (on site)

Note:

Please see the "Accessories" technical brochure for further details regarding the drive and control.

Some options are subject to a surcharge. For prices, please refer to the weinor awnings price list.

I/K/N 2000 Planning

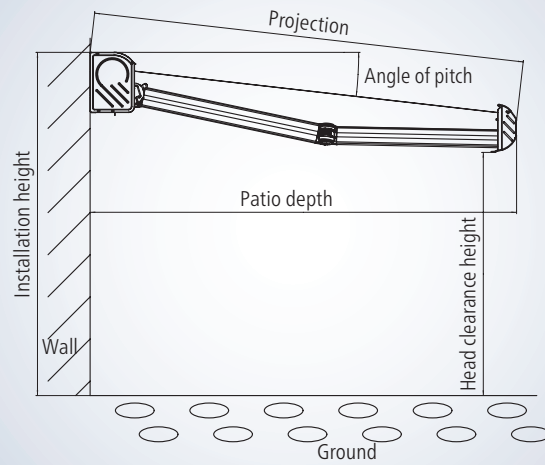

Site measurements – determining the projection and head clearance height

- Find the projection by looking in the “Projection” table for the terrace depth.
- Using the projection from the table and the required angle of pitch, consult the “head clearance height” table for the head clearance height. This head clearance height refers to an installation height of 300 cm.
- Add/subtract the difference between 300 cm and the actual installation height to/from the head clearance height in the table.

Determining the projection

Angle of pitch	Terrace depth in cm					
	150	200	250	300	350	400
5°	150	200	250	300	350	400
15°	160	210	260	310	360	–
25°	170	220	270	330	390	–

Projection in cm (rounded figures)

This table can be used to find the awning projection for any given horizontal patio depth.

Determining the head clearance height

Angle of pitch	Projection in cm					
	150	200	250	300	350	400
5°	270	270	270	260	260	250
15°	250	240	220	210	200	180
25°	220	200	180	160	140	120

Head clearance height in cm (rounded figures)

This table is used to find the head clearance heights for various projections when the angle of pitch is 5°, 15° or 25°.

This table is based on the example of an installation height of 300 cm (upper edge of awning).

Wall bracket

Sizes and bracket recommendations

Wall mounting on pressure-resistant surface

Minimum number of required wall brackets so that the function of the awning is ensured, regardless of the mounting surface. Selection of the brackets using the weinor bracket overview and using the maximum extraction forces of the fixings used!



Width in cm	Number of arms	Diagonal in 10 cm steps					
		up to 150	160-200	210-250	260-300	310-350	360-400
up to 200	2	2					
201-250	2	2	2				
251-300	2	2	2	2			
301-350	2	2	2	2	2		
351-400	2	2	2	2	2	2+1	
401-450	2	3	3	3	3	2+1	2+1
451-500	2	3	3	3	3	5	2+1
501-550	2	3	3	3	5	5	5
551-600	2	3	3	3	5	5	5
601-650	2	3	3	3	5	5	5
651-700	3	4	4	4	7	7	7

Overlapping possible, observe size limits!

Observe size limits; unit must have X more width than projection:

- in the case of 1 x wall bracket 85 mm or 1 x wall bracket 260 mm per arm:
X = 40 cm
- in the case of 2 x wall bracket 85 mm or 1 x wall bracket 295 mm per arm:
X = 62 cm
- in the case of 2 x wall bracket 260 per arm: X = 95 cm

- 2 2x wall bracket 85 mm
- 3 3x wall bracket 85 mm (1 x as a central bracket)
- 4 4x wall bracket 85 mm alternatively:
2x wall bracket 295 mm
- 5 5x wall bracket 85 mm (1 x as a central bracket) alternatively:
2x wall bracket 295 mm + 1x wall bracket 85 mm (as a central bracket)
- 2+1 2x wall bracket 260 mm + 1x wall bracket 85 mm (1 x as a central bracket)
- 7 7x wall bracket 85 mm (1 x as a central bracket)

Two brackets per arm required:

- a. projection \geq 310 cm
- b. width \geq 501 cm and projection \geq 260 cm

Use of central bracket dependent on width/projection:

- a. width \geq 401 cm
- b. projection \geq 310 cm

Position of wall brackets and cassette I/K 2000

Wall bracket 260 mm on both sides (KS1 and KS2)

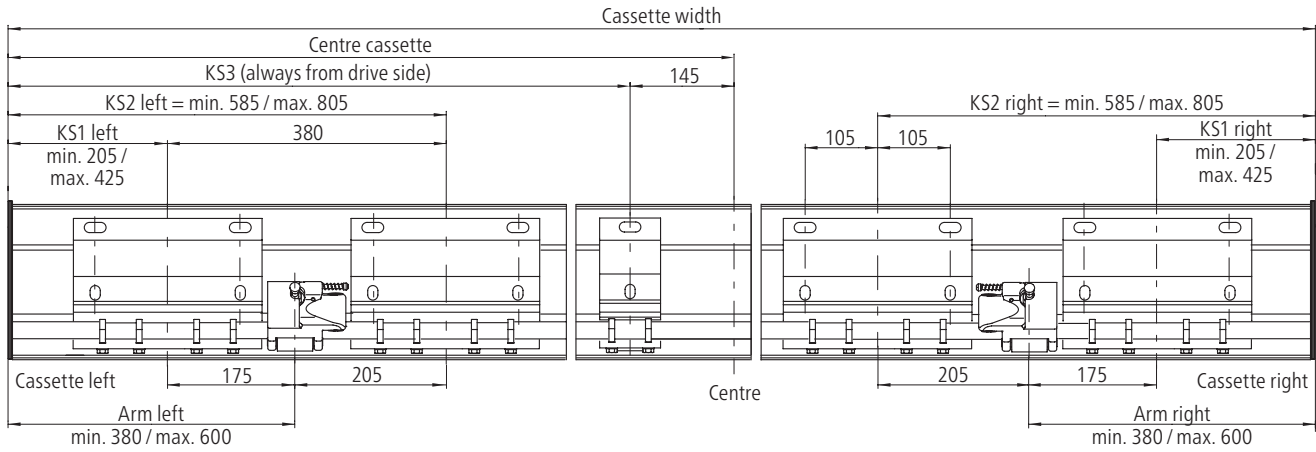

Wall bracket 260 mm outside (KS1)

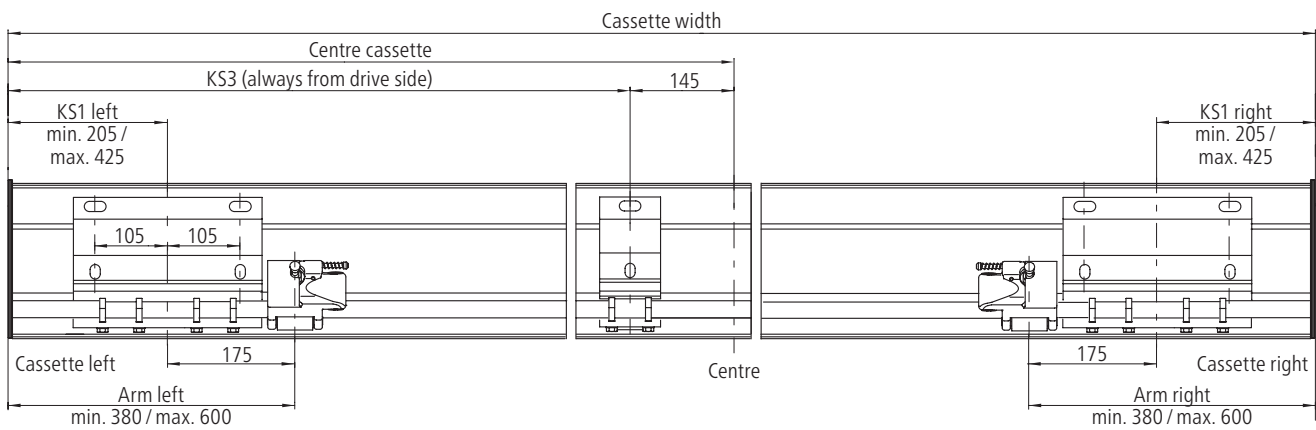

Wall bracket 260 mm inside (KS2)

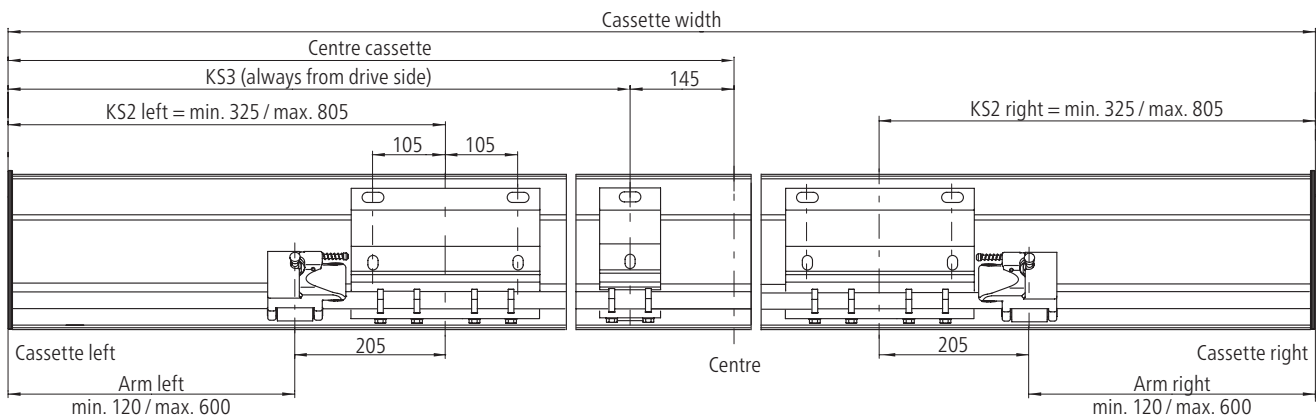

Notes:

- KS1 = outside bracket
- KS2 = inside bracket
- KS3 = centre bracket

Cross-sections

I2000 (without back plate)

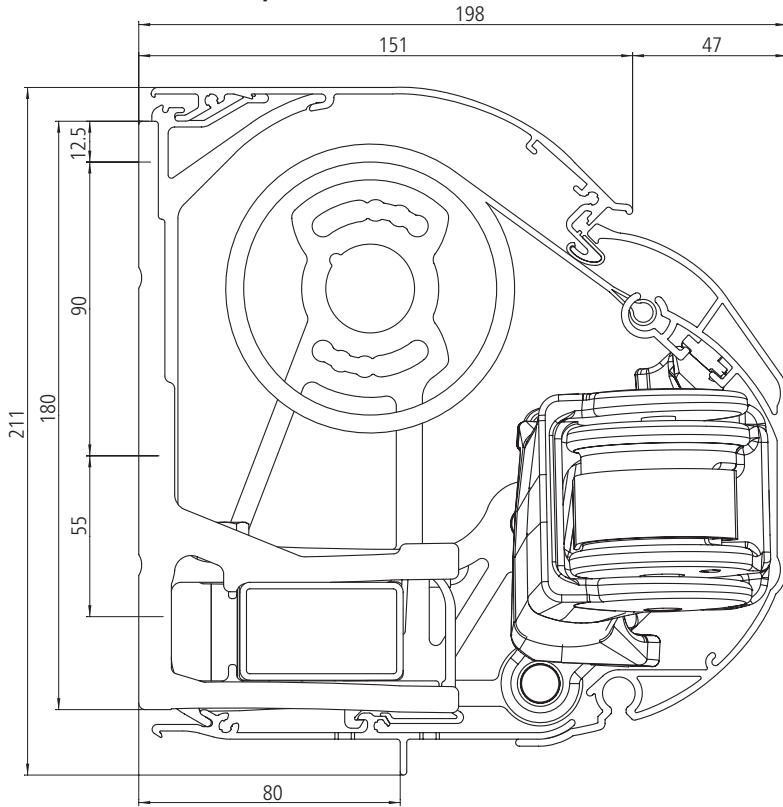

K2000 (with back plate)

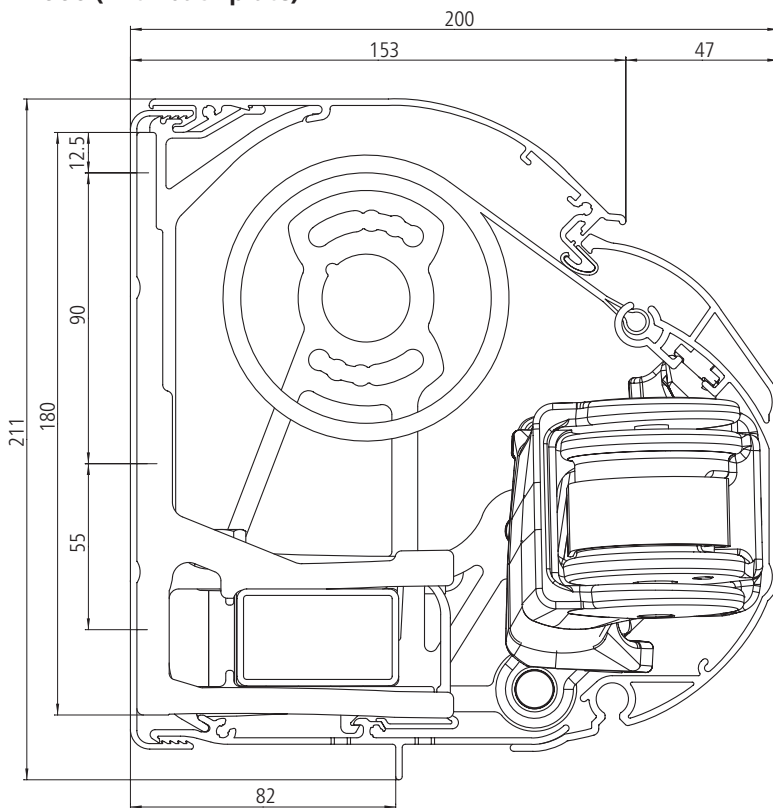

Cross-sections

I2000 (without back plate) niche installation

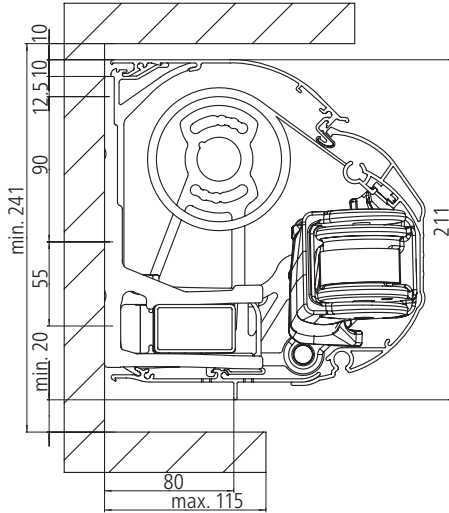

I2000 (without back plate) with LED Design light bar

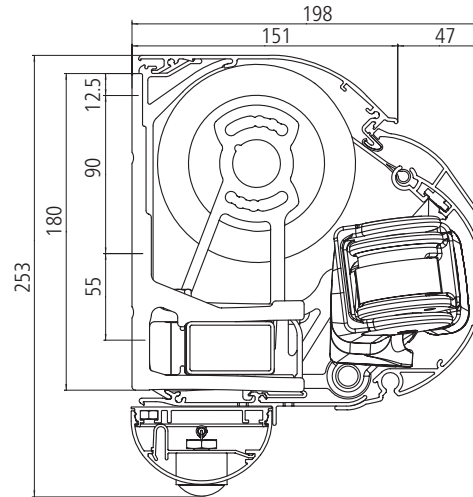

K2000 with gear box (with back plate)

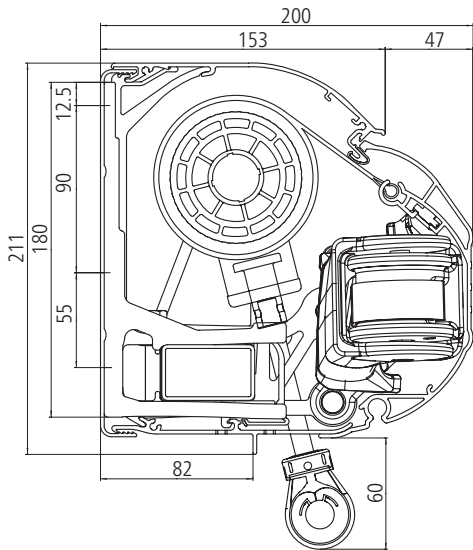

I2000 (with back plate) with LED Design light bar

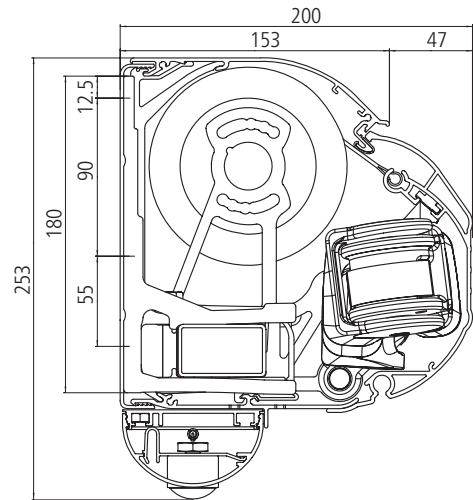

N2000

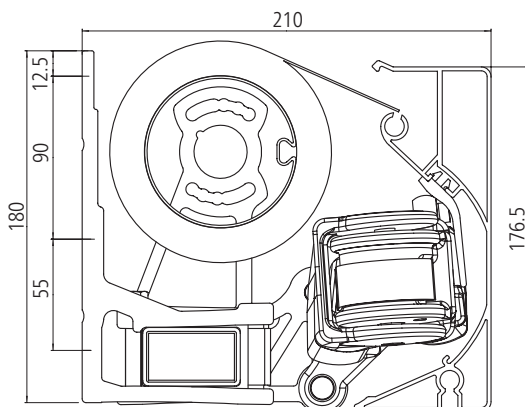

I/K/N 2000 Installation

Wall mounting – brackets



Wall bracket

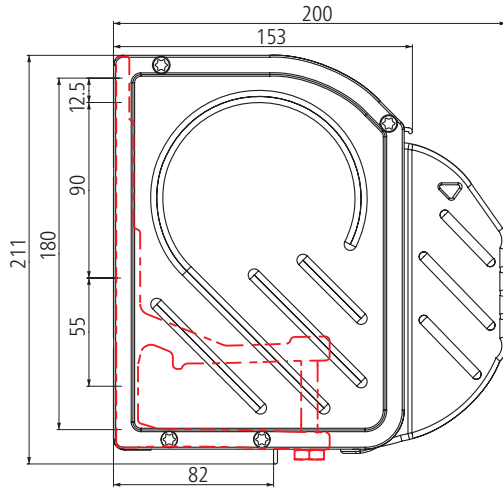

Wall bracket 85 mm

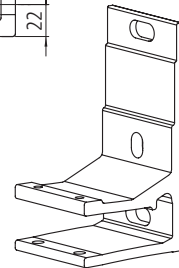
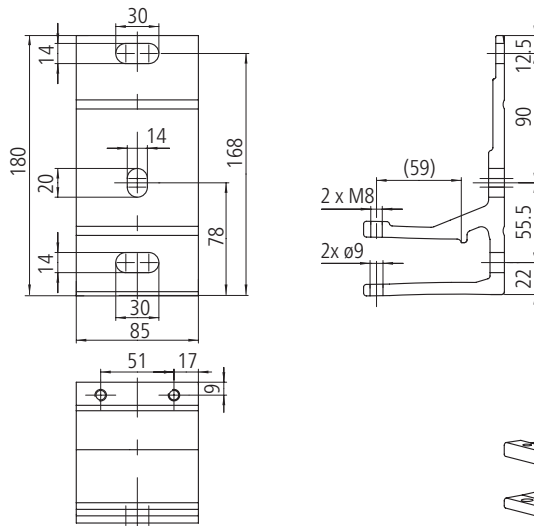

Wall bracket 295 mm (arm enclosure)

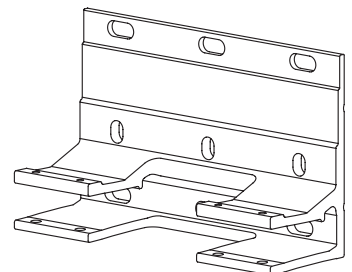
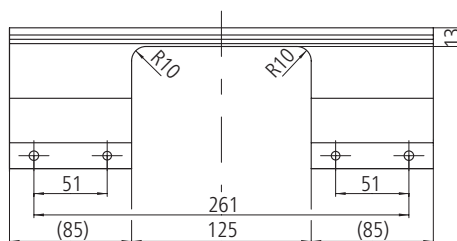
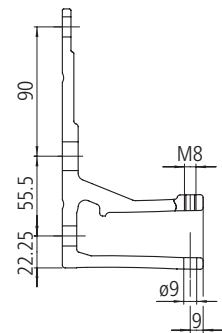
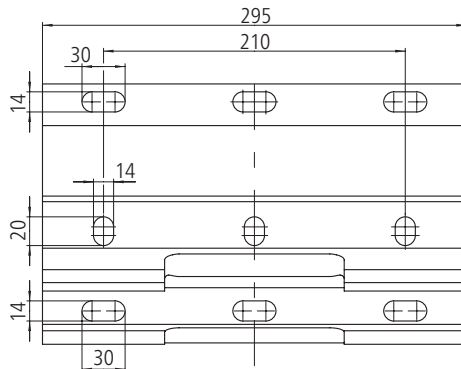

Wall mounting – brackets



Wall bracket 260 mm

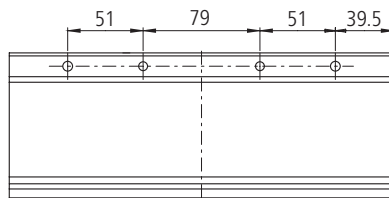
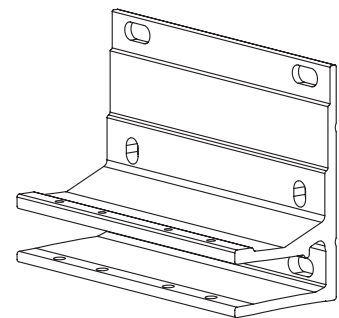
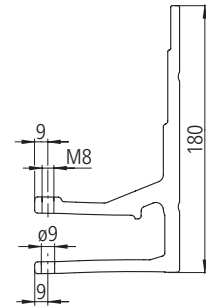
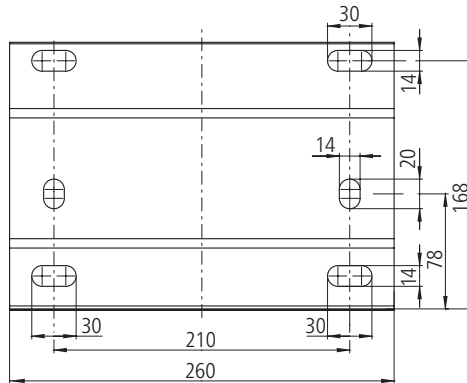

Baseplate (100 x 180 x 15 mm)

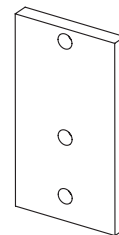
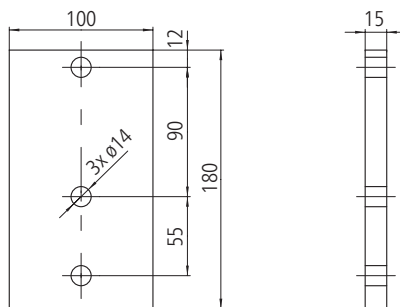

Baseplate (75 x 178 x 4 mm)

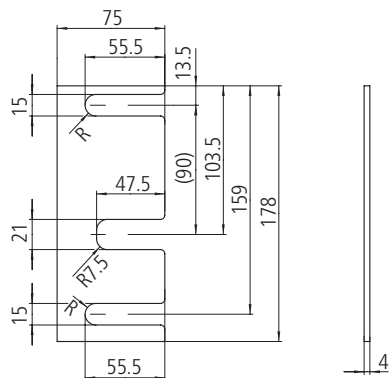

Wall mounting – mounting plates



Mounting plate 660 x 300 x 15 mm*

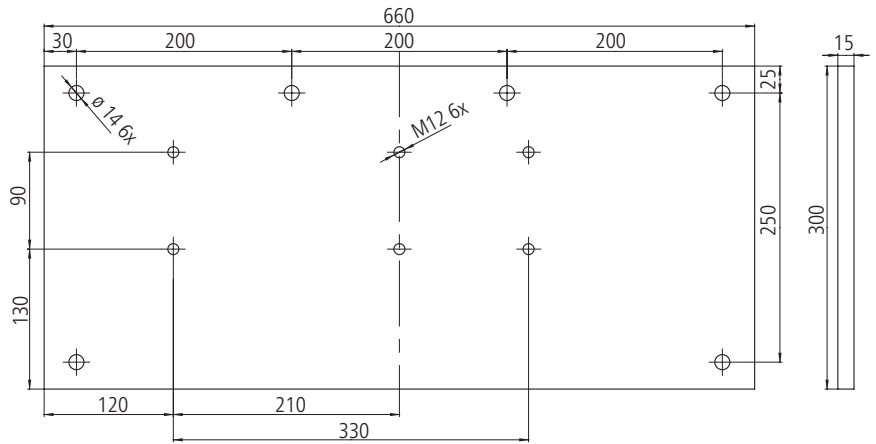
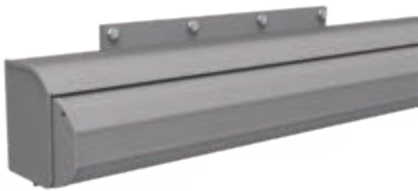

Position of the mounting plates using the I/K 2000 500 x 300 cm** as an example.



Mounting plate 660 x 390 x 15 mm*

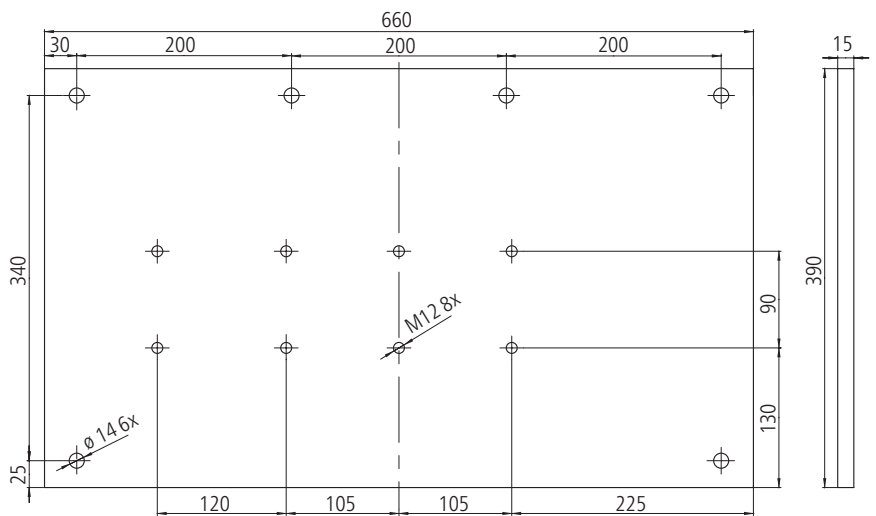

Position of the mounting plates using the I/K 2000 500 x 300 cm** as an example.



Mounting plate 250 x 290 x 15 mm

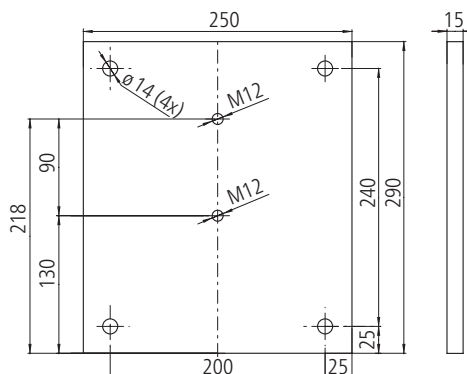

* Mounting plate also possible with 2 wall brackets 85 mm.

** Depending on the width of the awning, the positioning of the mounting plates may vary.

Minimum spacing distances for installation

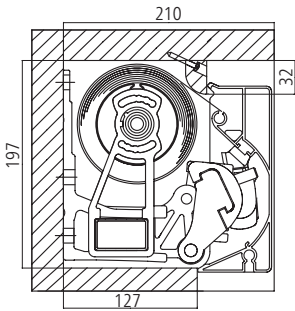

Type N niche installation

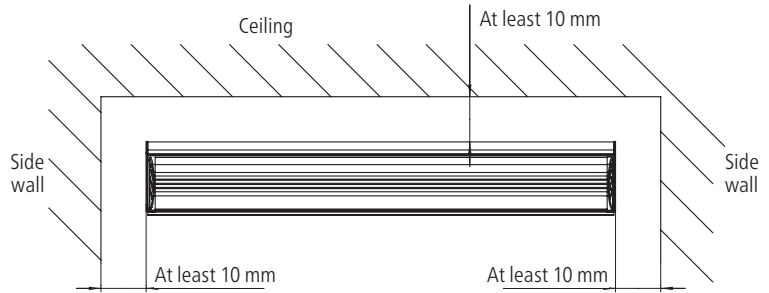

Type I und Type K with niche installation

Ceiling mounting



Ceiling bracket

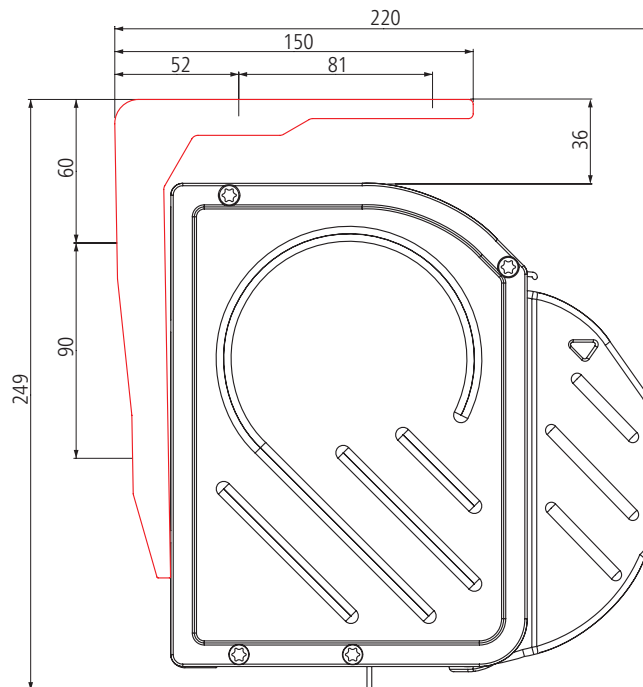

Ceiling bracket

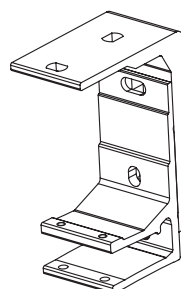
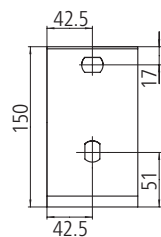
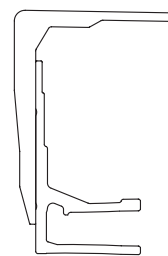
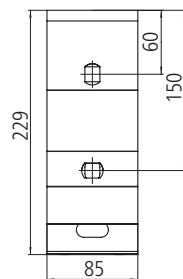

Ceiling mounting



Ceiling bracket 295 mm with wall bracket 260 mm

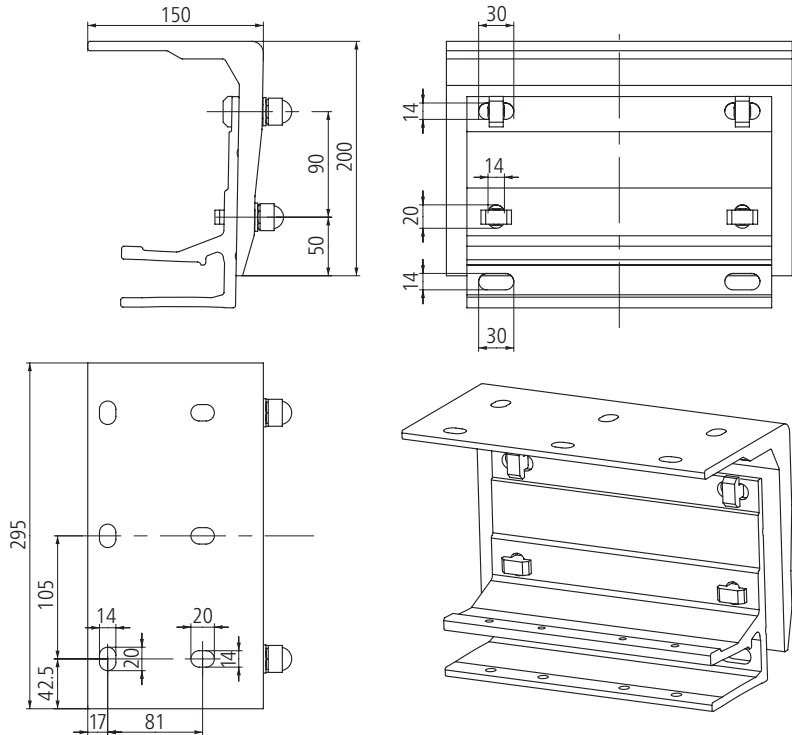

Ceiling bracket 295 mm with wall bracket 295 mm
(Cannot be used with three-arm constructions!)

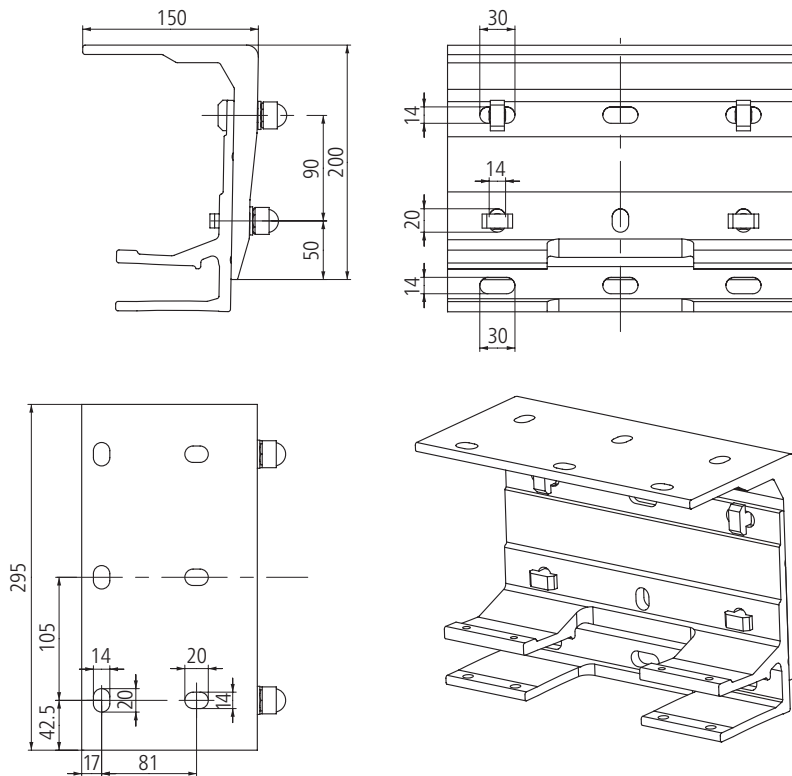

Rafter mounting



Rafter bracket with mounting plate



Rafter bracket and wall bracket, without mounting plate

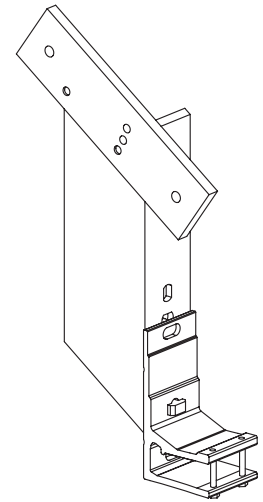
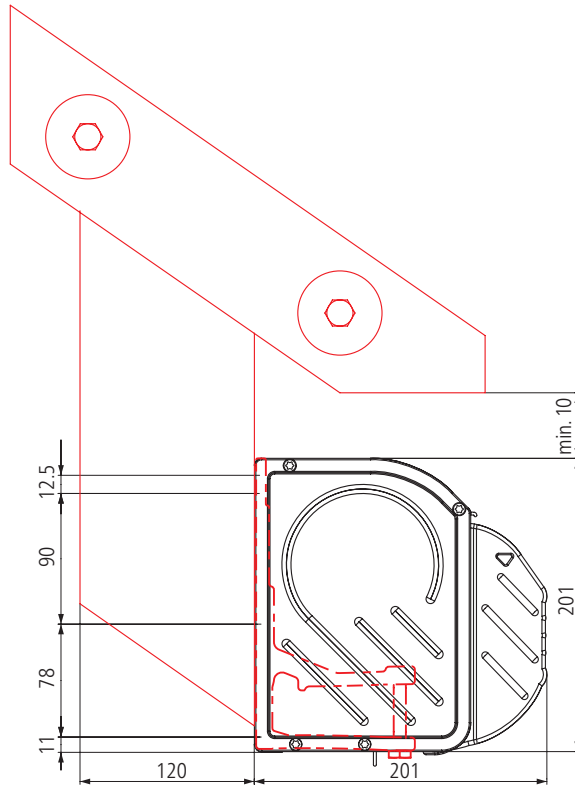

Rafter bracket with mounting plate
weinor recommends using a mounting plate for rafter brackets



Rafter bracket (right)

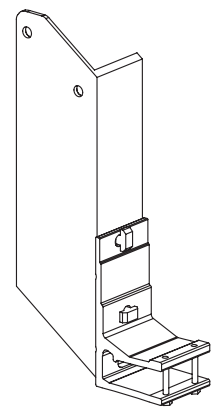
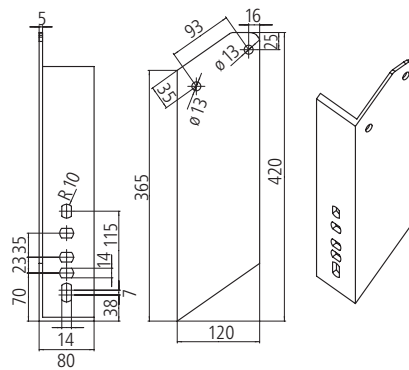

Rafter bracket without mounting plate

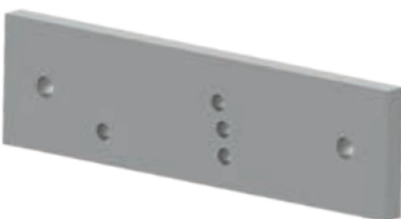

Mounting plate for 294 x 80 x 15 mm rafter bracket

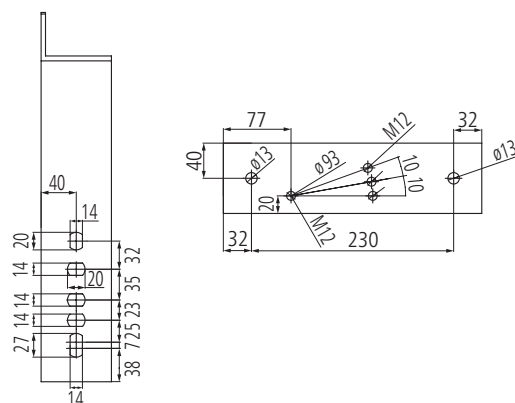

Extraction forces

The extraction force is the force with which the awning weight and the wind load pull on each upper and/or front fixing. The tables indicate this force in N per upper fixing. It varies depending on the awning size and the wall bracket / mounting plate used.

Selecting the wall bracket and anchoring system:

1. Consult relevant table for extraction force per fixing for selected awning size.
2. Select a wall bracket / mounting plate for which there is fixing material which can resist the indicated extraction force. Remember to take into account the spacing, the area which will be damaged if the fixing breaks out, the type of fixing material used and the mounting base.

Use the separate bracket overview for an exact planning of the awning attachment.

Extraction force in N per upper fixing for wall mounting

Brackets **without** mounting plates

Wall mounting with up to 200 mm facing (non-pressure-resistant surface)

Please observe the width to projection dimension limits for number of brackets per arm, as the width to projection ratio decreases when two brackets are used per arm.

For the variant "Type N 2000", the extraction forces increase by approximately 20%!

- 1 x wall bracket 85 mm per arm
or
- 2 x wall bracket 85 mm per arm
Number of fixings: 4 or 8
- 1 x wall bracket 260 mm per arm
or
- 2 x wall bracket 260 mm per arm
Number of fixings: 8 or 16
- 1 x wall bracket 295 mm per arm
Number of fixings: 12

Please note:

from a width of 401 cm or a projection of 310 cm additional

1 x wall bracket 85 mm as centre bracket is required.

This means an additional 2 fixings will be required always.

Taking the width to projection dimension limits into account, two brackets can also be used per arm instead of one bracket per arm.

Here, the indicated extraction force halves!

Does not apply to red-bordered cells and 295 mm wall bracket!

In the event of installation on a pressure-resistant surface, the indicated extraction force decreases (see bracket overview)

Width in cm	Projection in cm					
	150	200	250	300	350	400
200	1330					
	665					
	443					
250	1567	2338				
	783	1169				
	522	779				
300	1804	2693	3789			
	902	1347	1894			
	601	898	1263			
350	2041	3048	4283	5807		
	1020	1524	2141	2903		
	680	1016	1428	1936		
400	2278	3403	4777	6462	4116	
	1139	1701	2388	3231	2058	
	759	1134	1592	2154	2744	
450	2514	3757	5271	7117	4535	6472
	1257	1879	2636	3558	2268	3236
	838	1252	1757	2372	3023	4315
500	2751	4112	5765	7772	5595	7078
	1376	2056	2883	3886	2798	3539
	917	1371	1922	2591	3730	4719
550	2988	4467	6259	8423	6080	7684
	1494	2233	3130	4213	3040	3842
	996	1489	2086	2809	4053	5123
600	3225	4822	6753	9119	6565	8290
	1613	2411	3377	4559	3282	4145
	1075	1607	2251	3042	4376	5526
650	3462	5176	7247	9845	7050	8896
	1731	2588	3624	4923	3525	4448
	1154	1725	2416	3264	4700	5930
700	2597	3885	5363	7287	5299	6710
	1298	1942	2682	3644	2649	3355

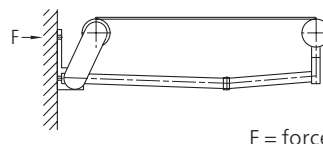

F = force

Extraction forces

Extraction force in N per upper fixing for wall mounting

Brackets **with** mounting plates

Wall mounting with up to 200 mm facing (non-pressure-resistant surface)

Please observe the width to projection dimension limits for number of brackets per arm, as the width to projection ratio decreases when two brackets are used per arm.

For the variant "Type N 2000", the extraction forces increase by approximately 20%!

- 1 x mounting plate 250 x 290 x 15 mm incl. 1 x wall bracket 85 mm per arm
Number of fixings: 8
- 1 x mounting plate 450 x 200 x 30 mm incl. 1 x wall bracket 85 mm per arm
or
- 1 x mounting plate 450 x 200 x 30 mm incl. 2 x wall bracket 85 mm per arm
Number of fixings: 12
- 1 x mounting plate 640 x 200 x 30 mm incl. 1 x wall bracket 85 mm per arm
or
- 1 x mounting plate 640 x 200 x 30 mm incl. 2 x wall bracket 85 mm per arm
Number of fixings: 24
- 1 x mounting plate 660 x 300 x 15 mm incl. 1 x wall bracket 85 mm per arm
or
- 1 x mounting plate 660 x 300 x 15 mm incl. 2 x wall bracket 85 mm per arm
Number of fixings: 12
- 1 x mounting plate 660 x 390 x 15 mm incl. 1 x wall bracket 85 mm per arm
or
- 1 x mounting plate 660 x 390 x 15 mm incl. 2 x wall bracket 85 mm per arm
Number of fixings: 12

Please note:

from a width of 401 cm or a projection of 310 cm additional

– for mounting plates with a thickness of **15 mm**

1 x wall bracket 85 mm incl.
1 x shim plate 100 x 180 x 15 mm
as central bracket required.

– for mounting plates with a thickness of **30 mm**

1 x wall bracket 85 mm incl.
2x shim plate 100 x 180 x 15 mm
as central bracket required.

This means an additional 2 fixings will be required always.

Taking the width to projection dimension limits into account, two brackets can also be used per arm instead of one bracket per arm.

This has no impact on the extraction force! Does not apply to 250 x 290 x 15 mm mounting plate!

In the case of red-bordered cells, the bracket sub-assemblies are equipped with two brackets per arm.

Width in cm	Projection in cm					
	150	200	250	300	350	400
200	126					
	273					
	136					
	121					
250	89					
	149	221				
	321	477				
	161	239				
300	143	213				
	105	156				
	171	255	358			
	370	550	771			
350	185	275	385			
	164	245	344			
	121	180	253			
	194	289	405	549		
400	418	622	871	1179		
	209	311	436	589		
	186	277	389	527		
	137	204	286	387		
450	216	322	452	610		
	467	694	972	1312	1669	
	233	347	486	656	834	
	208	309	434	586	746	
500	153	227	319	431	548	
	239	356	498	672		
	515	767	1072	1445	1838	2620
	258	383	536	722	919	1310
550	229	342	478	645	822	1172
	168	251	352	475	604	862
	261	389	545	734		
	564	839	1173	1578	2268	2865
600	282	420	586	789	1134	1433
	251	374	523	705	1014	1282
	184	275	385	518	746	942
	284	423	592			
650	612	911	1273	1711	2465	3111
	306	456	637	855	1232	1555
	272	406	568	764	1102	1391
	200	299	418	562	810	1023
700	306	457	639			
	661	984	1374	2079	2661	3356
	331	492	687	1039	1331	1678
	294	438	613	928	1190	1501
750	216	322	451	683	875	1104
	329	490	685			
	710	1056	1474	2232	2858	3601
	355	528	737	1116	1429	1801
800	315	471	658	997	1277	1611
	232	346	484	733	939	1184
	246	368	576			
	532	793	1240			
850	266	396	620			
	237	353	553	750	960	1215
	174	260	407	551	706	894

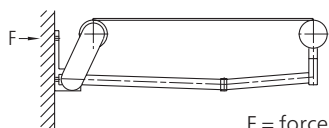

In the event of installation on a pressure-resistant surface, the indicated extraction force decreases (see bracket overview)

Extraction forces

Extraction force in N per front fixing for ceiling mounting

Please observe the width to projection dimension limits for number of brackets per arm, as the width to projection ratio decreases when two brackets are used per arm.

For the variant "Type N 2000", the extraction forces increase by approximately 20%!

- 1 x ceiling bracket 85 mm incl.
1 x bracket 85 mm per arm
or
- 2x ceiling bracket 85 mm incl.
2x bracket 85 mm per arm
Number of fixings:
4 or 8
- 1 x ceiling bracket 295 mm incl.
1 x bracket 260 mm per arm
or
- 2x ceiling bracket 295 mm incl.
2x bracket 260 mm per arm
Number of fixings:
12 or 24
- 1 x ceiling bracket 295 mm incl.
1 x bracket 295 mm per arm
Number of fixings: 12

Please note:
from a width of 401 cm or a projection of 310 cm additional
1 x ceiling bracket 85 mm incl.
1 x wall bracket 85 mm
as central bracket required.
This means an additional 2 fixings will be required always.

Taking the width to projection dimension limits into account, two brackets can also be used per arm instead of one bracket per arm.

Here, the indicated extraction force halves!

Does not apply to red-bordered cells and combination of wall bracket 295 mm with ceiling bracket 295 mm!

Width in cm	Projection in cm					
	150	200	250	300	350	400
200	1000					
	341					
	340					
250	1173	1719				
	398	580				
	397	579				
300	1345	1975	2754			
	455	665	925			
	455	665	924			
350	1518	2230	3108	4196		
	513	750	1043	1406		
	513	750	1043	1405		
400	1691	2486	3462	4664	2951	
	571	836	1161	1562	995	
	570	835	1161	1561	1975	
450	1802	2679	3752	5065	3249	4621
	619	912	1270	1708	1094	1552
	619	911	1269	1708	2173	3088
500	1970	2930	4101	5529	3990	5051
	676	996	1387	1864	1342	1696
	676	996	1387	1863	2668	3376
550	2144	3186	4456	3020	4337	5485
	736	1083	1507	1019	1458	1841
	735	1083	1507	2021	2900	3665
600	2312	3437	4806	3648	4681	5915
	792	1168	1625	1229	1573	1984
	792	1167	1624	2441	3129	3952
650	2479	3687	5155	3915	5024	6345
	849	1252	1742	1318	1688	2128
	849	1252	1742	2619	3359	4239
700	1874	2782	4328	2951	3784	4795
	641	944	1459	994	1272	1609



F = force

Shear forces

Shear forces in N per fixing for rafter mounting

Please observe the width to projection dimension limits for number of brackets per arm, as the width to projection ratio decreases when two brackets are used per arm.

For the variant "Type N 2000", the shear forces increase by approximately 20%!

Rafter brackets are available as both left and right handed

- 1x rafter bracket incl.
1x wall bracket 85 mm per arm
or
- 2x rafter bracket incl.
2x wall bracket 85 mm per arm
Applies to two brackets per arm on a rafter.
or
- 2x rafter bracket incl.
2x wall bracket 85 mm per arm
Applies to two brackets per arm, each with separate rafters.
- 1x rafter bracket with
1x mounting plate for rafter incl.
1x wall bracket 85 mm per arm
or
- 2x rafter bracket with
2x mounting plate for rafter incl.
2x wall bracket 85 mm per arm
Applies to two brackets per arm on a rafter.
or
- 2x rafter bracket with
2x mounting plate for rafter incl.
2x wall bracket 85 mm per arm
Applies to two brackets per arm, each with separate rafters.

Please note:
from a width of 401 cm or a projection of 310 cm additional
1x rafter bracket incl.
1x wall bracket 85 mm
as central bracket required.

Taking the width to projection dimension limits into account, two brackets can also be used per arm instead of one bracket per arm.

Here, the indicated extraction force halves!

Applies only in the case of two brackets per arm on separate rafters respectively! If two brackets per arm are mounted on one rafter, the shear force does not decrease!

weinor recommends the use of rafter brackets with mounting plate!
In the case of rafter mounting, the fixings are included in the order.

Width in cm	Projection in cm					
	150	200	250	300	350	400
200	1395					
	639					
250	1637	2386				
	746	1051				
300	1879	2742	3805			
	853	1204	1638			
350	2122	3098	4295	5774		
	960	1357	1845	2448		
400	2364	3454	4786	6420	8018	
	1066	1510	2052	2719	4009	3298
450	2545	3747	5211	6998	8831	12572
	1112	1600	2195	2921	4415	6286
500	2782	4098	5697	7639	10880	13747
	1214	1748	2397	3186	5440	6873
550	3025	4455	6188		8221	11823
	1321	1902	2605		4110	5911
600	3262	4806	6674		3392	4850
	1423	2049	2808		1696	2425
650	3500	5157	7160		9969	12764
	1525	2197	3010		4984	6382
700	2641	3887	6020		4103	5234
	1161	1667	2533		2051	2617
					10701	13704
					5350	6852
					4402	5618
					2201	2809
					8055	10310
					4027	5155
					3320	4233
					1660	2116

